

Handreguliertventile „Baureihe HR“ Einbauanleitung

Funktion:

Oventrop Heizkörper-Handreguliertventile „Baureihe HR“ ermöglichen eine exakte manuelle Regulierung der Raumtemperatur. Die Wärmeabgabe des Heizkörpers erfolgt proportional zur Einstellung des Handrades.

Verwendungsbereich:

Einrohr- und Zweirohr-Zentralheizungsanlagen, max. Betriebsdruck p_s : 10 bar, Betriebstemperatur t_s : 2°C bis 120°C (kurzzeitig bis 130 °C), unabhängig von der Beheizungsart, sowie für Dampf 0,5 bar, 110°C.

Eckform:

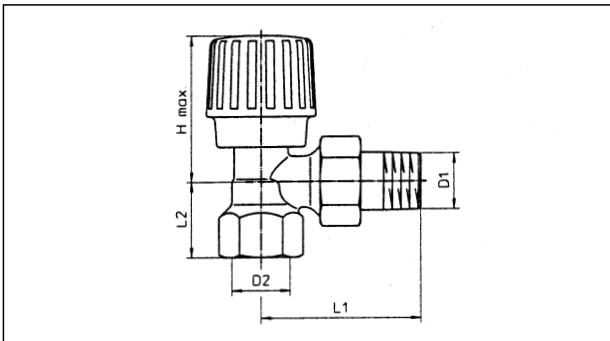

DN	D ₁ EN 10226-1	D ₂ EN 10226-1	L ₁	L ₂	H _{max.}	Artikel-Nr.
10	R 3/8	Rp 3/8	51,5	22,5	53,5	119 05 53
15	R 1/2	Rp 1/2	57,5	27,5	55	119 05 54
20	R 3/4	Rp 3/4	65,5	29	57,5	119 05 56

Anschluss normalerweise für Gewinderohr. Für die Verbindung genormter Rohre aus Kupfer, Edelstahl, Präzisionsstahl und Kunststoff an die Handreguliertventile sind bei Oventrop die Verbindungselemente zu beziehen. Bei Verwendung von Klemmringverschraubungen müssen die „Ofix“ Klemmringverschraubungen eingesetzt werden.

Die Anbindung von Oventrop „Copipe“ Mehrschicht-Verbundrohr erfolgt mittels der „Cofit S“ Klemmringverschraubungen oder „Cofit P“ Pressfittings.

Ausführung:

Gehäuse aus Messing, vernickelt. Einbaumaße nach DIN 3842. Innenteile und Verschraubung aus Messing. Spindelabdichtung durch doppelten O-Ring aus EPDM. Handrad aus wärmebeständigem, schlagfestem Kunststoff.

Durchgangsform:

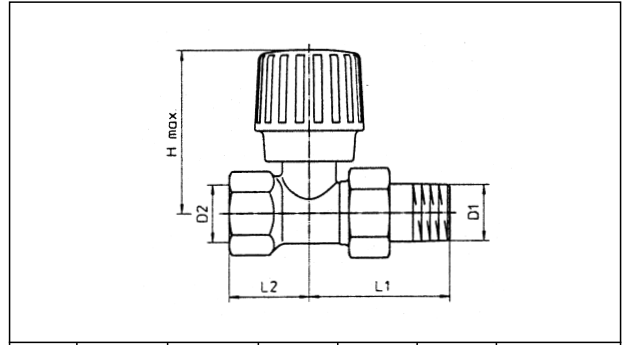

DN	D ₁ EN 10226-1	D ₂ EN 10226-1	L ₁	L ₂	H _{max.}	Artikel-Nr.
10	R 3/8	Rp 3/8	51	23,5	61	119 06 53
15	R 1/2	Rp 1/2	50,5	29	61	119 06 54
20	R 3/4	Rp 3/4	61,5	29	62	119 06 56

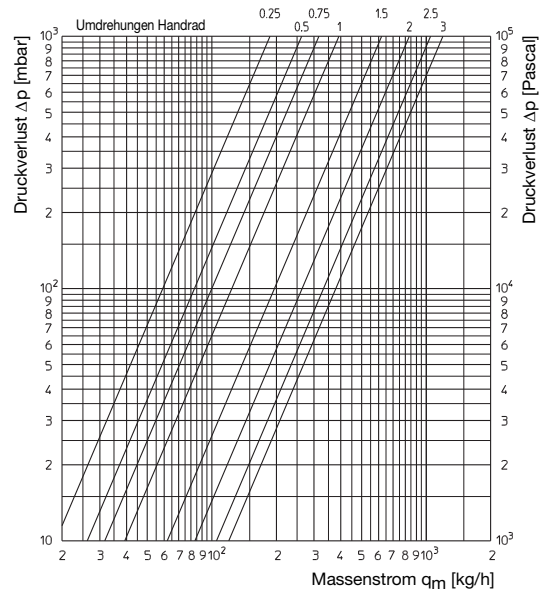
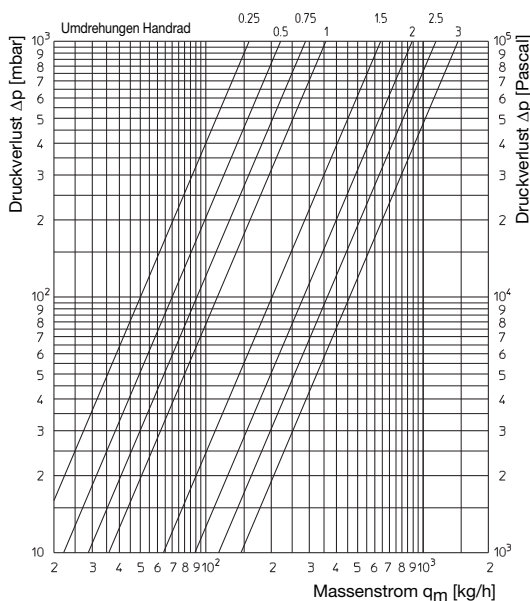

OVENTROP GmbH & Co. KG
Paul-Oventrop-Straße 1
D-59939 Olsberg
Telefon +49 (0) 29 62 82-0
Telefax +49 (0) 29 62 82-400
E-Mail mail@oventrop.de
Internet www.oventrop.com

Eine Übersicht der weltweiten Ansprechpartner finden Sie unter www.oventrop.de.

Manual radiator valves "Series HR" Installation instructions

Function:

Oventrop manual radiator valves permit a precise manual control of the room temperature. The radiator heat output is proportional to the setting of the handwheel. A special profile valve disc permits a precise regulation of the flow.

Application:

One and two pipe central heating systems, max. working pressure p_s : 10 bar, working temperature t_s : 2 °C up to 120 °C (for short periods up to 130 °C), irrespective of the type of heat source and steam 0.5 bar, 110 °C.

Connection for threaded pipes. For the connection of standardized pipes made of copper, stainless steel, precision steel and plastic to the manual radiator valves, the Oventrop connection elements have to be used. When using compression fittings, the "Ofix" compression fittings are to be used. Connection of the Oventrop composition pipe "Copipe" by use of the screwed fittings "Cofit S" or the press fittings "Cofit P".

Model:

Body made of nickel plated brass. Measures according to DIN 3842. Inner parts and coupling made of brass. Stem with double EPDM O-ring seal. Handwheel made of heat proof and impact resistant plastic compound.

Angle pattern:

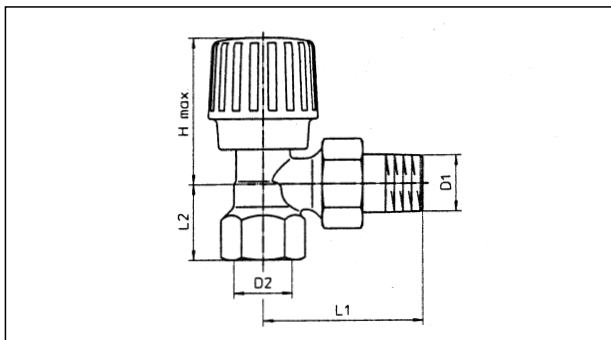

DN	D ₁ EN 10226-1	D ₂ EN 10226-1	L ₁	L ₂	H _{max.}	Item no.
10	R 3/8	Rp 3/8	51,5	22,5	53,5	119 05 53
15	R 1/2	Rp 1/2	57,5	27,5	55	119 05 54
20	R 3/4	Rp 3/4	65,5	29	57,5	119 05 56

Straight pattern:

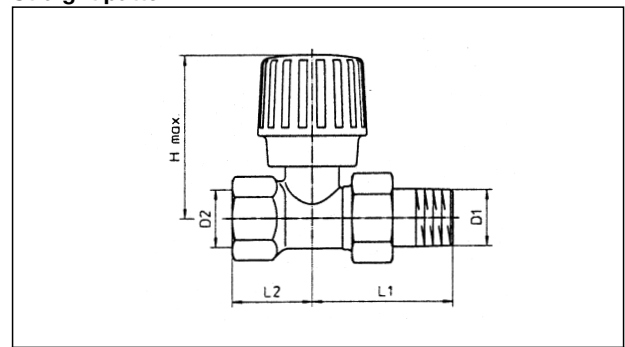

DN	D ₁ EN 10226-1	D ₂ EN 10226-1	L ₁	L ₂	H _{max.}	Item no.
10	R 3/8	Rp 3/8	51	23,5	61	119 06 53
15	R 1/2	Rp 1/2	50,5	29	61	119 06 54
20	R 3/4	Rp 3/4	61,5	29	62	119 06 56

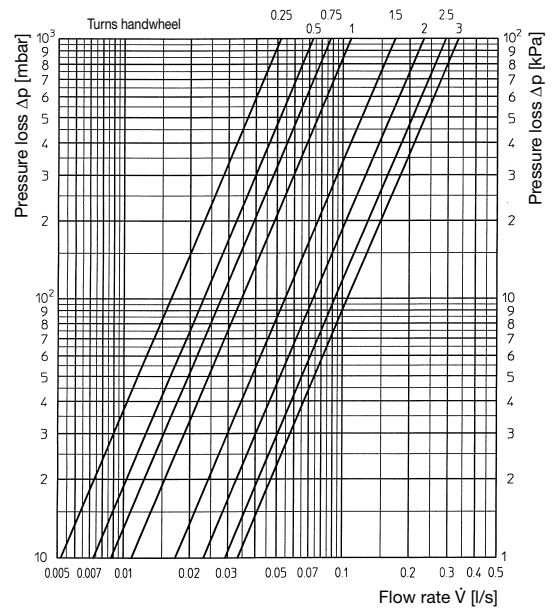
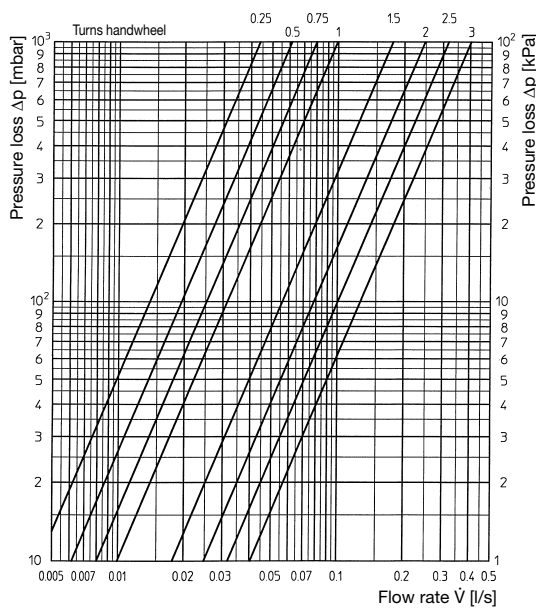

Fonctionnement:

Les robinets manuels Oventrop de la série HR permettent un réglage manuel précis de la température ambiante. L'exothermie du radiateur est proportionnelle au réglage de la poignée. Cette précision est due à la forme spéciale du clapet.

Domaine d'application:

Installations de chauffage central mono- et bitubes, pression de service max. p_s : 10 bars, température de service t_s : 2 °C jusqu'à 120°C (pour périodes courtes jusqu'à 130 °C), pour toutes sortes de combustible et pour vapeur 0,5 bar, 110 °C.

Modèle équerre:

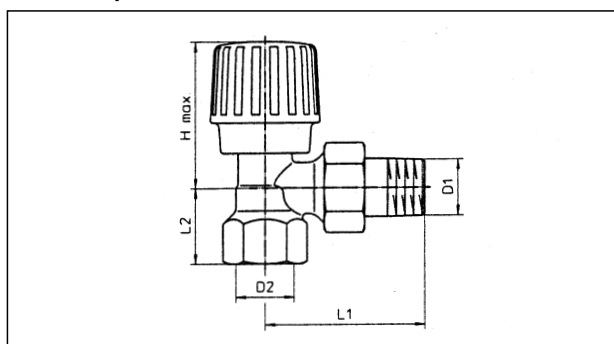

DN	D ₁ EN 10226-1	D ₂ EN 10226-1	L ₁	L ₂	H _{max.}	Réf.
10	R 3/8	Rp 3/8	51,5	22,5	53,5	119 05 53
15	R 1/2	Rp 1/2	57,5	27,5	55	119 05 54
20	R 3/4	Rp 3/4	65,5	29	57,5	119 05 56

Raccordement standard pour tubes filetés. Pour le raccordement de tubes standardisés en cuivre, acier inoxydable, acier de précision et plastique aux robinets manuels, les éléments de raccordement de la société Oventrop sont à utiliser. Lors de l'utilisation de raccords à serrage, les raccords à serrage «Ofix» doivent être utilisés.

Raccordement du tube multi-couches Oventrop «Copipe» à l'aide des raccords à serrage «Cofit S» ou des raccords à sertir «Cofit P».

Modèle:

Corps en laiton nickelé. Encombrements selon DIN 3842. Pièces intérieures et raccord en laiton. Etanchéité de la tige par double joint torique en EPDM. Poignée manuelle en plastique résistant au chocs et à la chaleur.

Modèle droit:

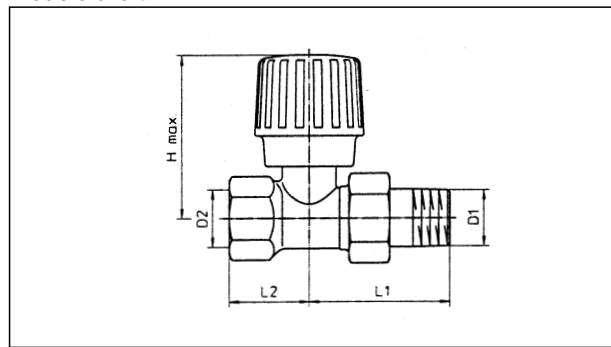

DN	D ₁ EN 10226-1	D ₂ EN 10226-1	L ₁	L ₂	H _{max.}	Réf.
10	R 3/8	Rp 3/8	51	23,5	61	119 06 53
15	R 1/2	Rp 1/2	50,5	29	61	119 06 54
20	R 3/4	Rp 3/4	61,5	29	62	119 06 56

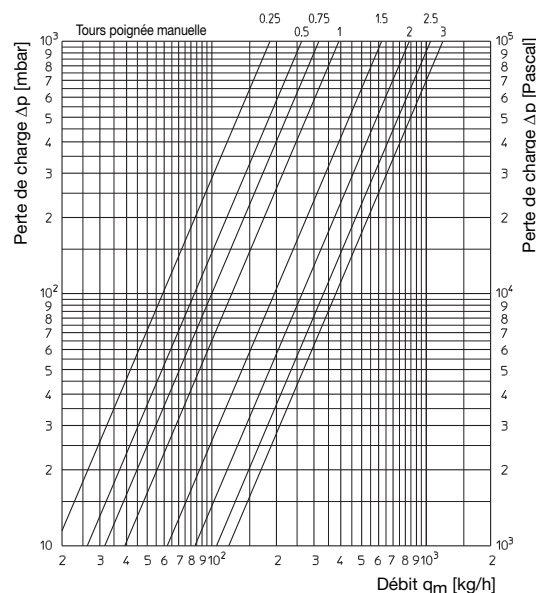
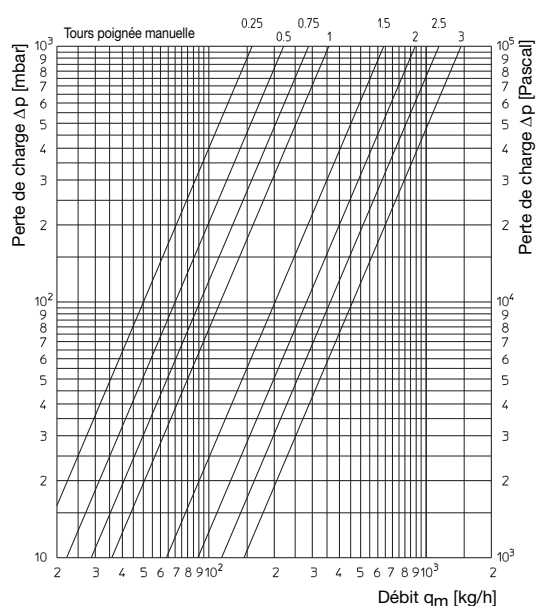

Handregelkraan "Reeks HR"

Inbouwhandleiding

Functie:

Oventrop radiator-handregelkraan "Reeks HR" maakt een exacte manuele regeling van de kamertemperatuur mogelijk. De warmteafgave van de radiator is proportioneel volgens de instelling van de handknop.

Gebruik:

1-pijps- en 2-pijps CV-Installaties, max. bedrijfsdruk p_g : 10 bar, bedrijfstemperatuur t_g : 2°C tot 120°C (kortstondig tot 130°C), onafhankelijk van de verwarmingsmethode, evenals voor stroom 0,5 bar, 110°C.

Aansluiting normaal voor buizen met draadaansluiting. Voor de verbinding van leidingen van koper, RVS, precisie staal en kunststof aan de handregelkraan, zijn bij Oventrop de verbindingselementen te verkrijgen. Bij gebruik van klemkoppelingen moeten de "Ofix" klemkoppelingen gebruikt worden. De aansluiting van Oventrop "Copipe" multi-lagen verbindingbuis gebeurt door middel van de "Cofit S" klemringkoppelingen of "Cofit P" persfittingen.

Uitvoering:

Huis uit messing, vernikkeld. Inbouwmaat volgens DIN 3842. Binnendelen en koppelingen uit messing. Spindelafdichting door dubbele O-ring uit EPDM. Handknop uit warmtebestendig, slagvast kunststof.

Haaks model:

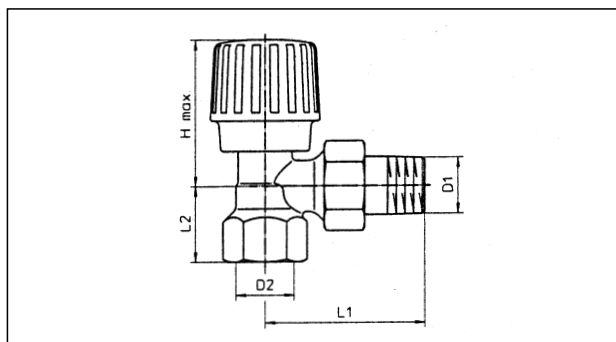

DN	D ₁ EN 10226-1	D ₂ EN 10226-1	L ₁	L ₂	H _{max.}	Art.-Nr.
10	R 3/8	Rp 3/8	51,5	22,5	53,5	119 05 53
15	R 1/2	Rp 1/2	57,5	27,5	55	119 05 54
20	R 3/4	Rp 3/4	65,5	29	57,5	119 05 56

Recht model:

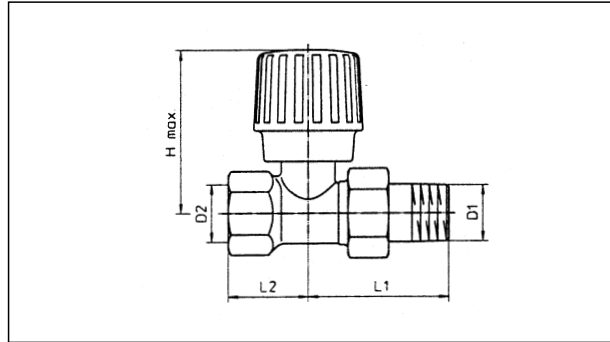

DN	D ₁ EN 10226-1	D ₂ EN 10226-1	L ₁	L ₂	H _{max.}	Art.-Nr.
10	R 3/8	Rp 3/8	51	23,5	61	119 06 53
15	R 1/2	Rp 1/2	50,5	29	61	119 06 54
20	R 3/4	Rp 3/4	61,5	29	62	119 06 56

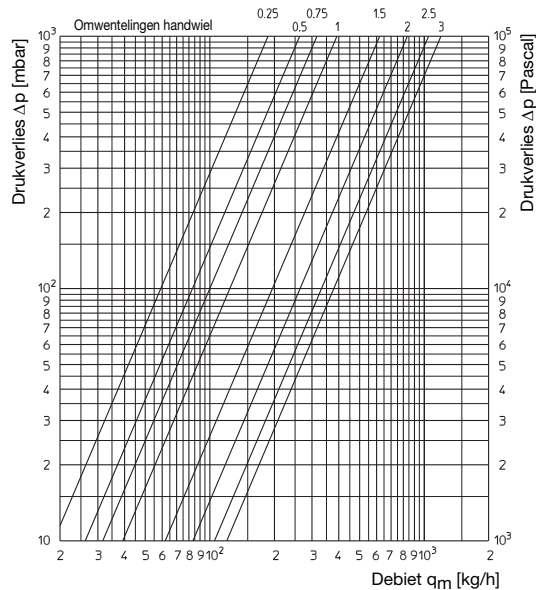
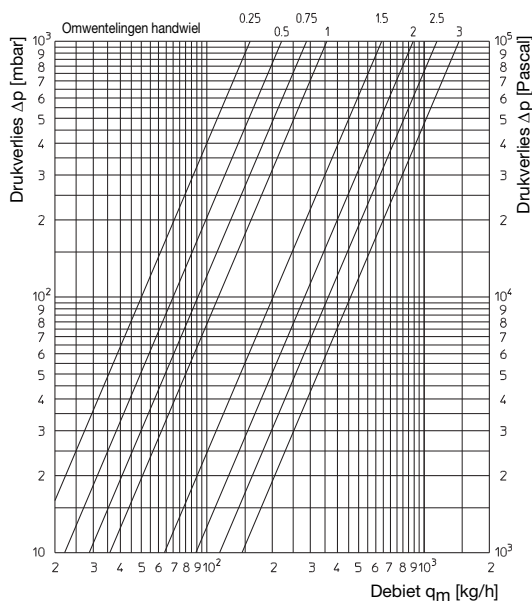

Funzione:

Le valvole Oventrop a regolazione manuale della „Serie HR”, permettono una regolazione precisa della temperatura d'ambiente. La trasmissione calorica del radiatore avviene in modo proporzionale all'impostazione del volantino.

Campo d'impiego:

Impianti di riscaldamento centralizzati mono o bitubo con pressione massima di mandata p_s : 10 bar, temperatura di mandata t_s : da 2 a 120°C (per breve tempo fino a 130°C), indipendentemente dal tipo di alimentazione, adatto anche per vapore 0,5 bar, 110°C.

Attacco per tubo filettato. Utilizzando raccordi di serraggio e dadi Oventrop e' possibile il collegamento anche a tubi rame-, acciaio di precisione e acciaio inossidabile. Il collegamento al tubo multistrato Oventrop „Copipe” avviene mediante raccordi di serraggio „Cofit S” o „Cofit P”.

Versioni:

Corpo in ottone, nichelato. Dimensioni sec. DIN 3842. parti interne e attacchi in ottone. Doppia guarnizione O-R dell'asta in EPDM. Volantino in materiale termoresistente e antiurto.

Valvola ad angolo:

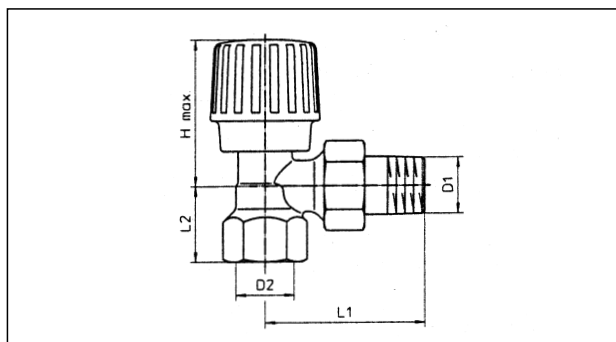

DN	D ₁ EN 10226-1	D ₂ EN 10226-1	L ₁	L ₂	H _{max.}	Cod. art.
10	R 3/8	Rp 3/8	51,5	22,5	53,5	119 05 53
15	R 1/2	Rp 1/2	57,5	27,5	55	119 05 54
20	R 3/4	Rp 3/4	65,5	29	57,5	119 05 56

Valvola diretta:

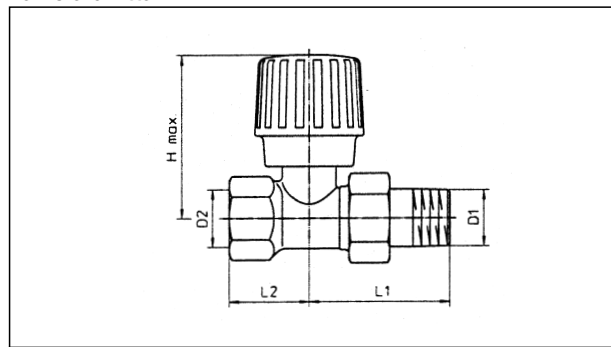

DN	D ₁ EN 10226-1	D ₂ EN 10226-1	L ₁	L ₂	H _{max.}	Cod. art.
10	R 3/8	Rp 3/8	51	23,5	61	119 06 53
15	R 1/2	Rp 1/2	50,5	29	61	119 06 54
20	R 3/4	Rp 3/4	61,5	29	62	119 06 56

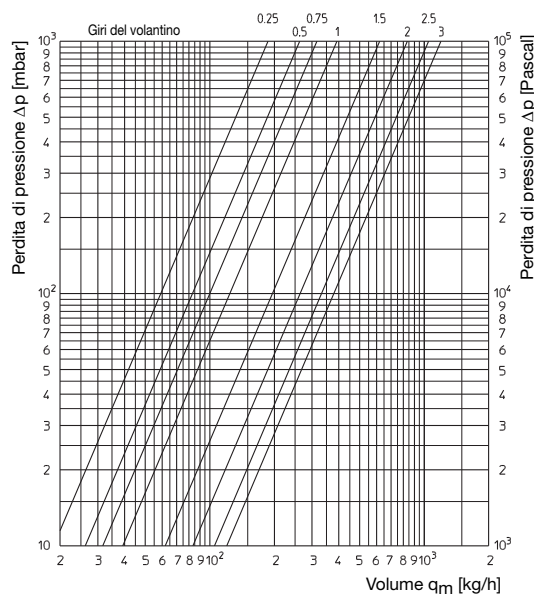
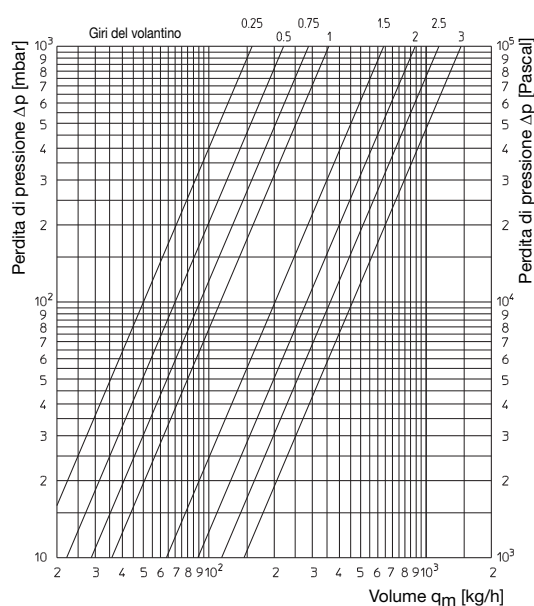

Funcionamiento:

Las válvulas manuales permiten una regulación manual precisa de la temperatura ambiente. La potencia calorífica del radiador es proporcional al reglaje del cabezal. Esta precisión es debida a la forma especial del asiento.

Campo de aplicación:

Instalaciones de calefacción central mono y bitubo, máx. presión de trabajo p_s : 10 bar, temperatura de trabajo t_s : 2°C por encima de 120°C (para períodos cortos hasta 130°C), sin tener en cuenta el tipo de combustible y vapor 0,5 bar, 110°C.

Conexión para tubos roscados. También se puede conectar a tubos de cobre, acero inoxidable, acero de precisión y plástico mediante los racores Oventrop. Cuando se utilizan racores de compresión, deben ser de la serie "Ofix". Conexión del tubo multicapa "Copipe" de Oventrop con ayuda de racores roscados "Cofit S" o racores de compresión "Cofit P".

Modelo:

Cuerpo en latón niquelado. Fabricado según DIN 3842. Internos y racor en latón. Estanqueidad por doble junta tórica en EPDM. Volante en plástico resistente al calor y a los golpes.

Modelo escuadra:

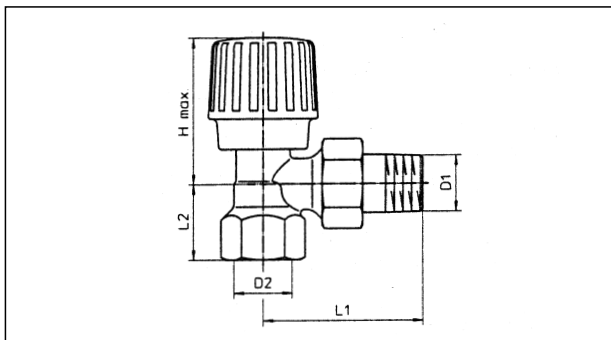

DN	D ₁ EN 10226-1	D ₂ EN 10226-1	L ₁	L ₂	H _{max.}	Art.-Nr.
10	R 3/8	Rp 3/8	51,5	22,5	53,5	119 05 53
15	R 1/2	Rp 1/2	57,5	27,5	55	119 05 54
20	R 3/4	Rp 3/4	65,5	29	57,5	119 05 56

Modelo recto:

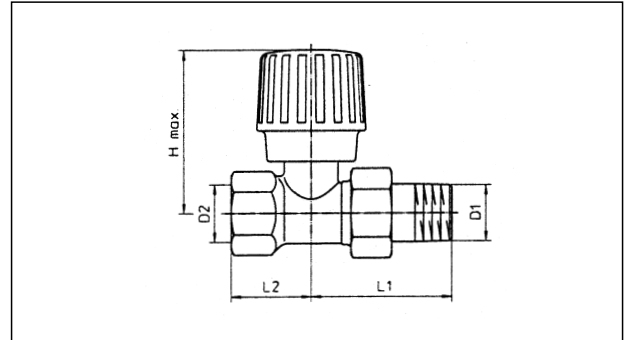

DN	D ₁ EN 10226-1	D ₂ EN 10226-1	L ₁	L ₂	H _{max.}	Art.-Nr.
10	R 3/8	Rp 3/8	51	23,5	61	119 06 53
15	R 1/2	Rp 1/2	50,5	29	61	119 06 54
20	R 3/4	Rp 3/4	61,5	29	62	119 06 56

