

"Combi-System" – Screwed connection

"Copipe" composition pipe
"Cofit S" connections- and fittings programme

1 Application:

Due to the universal application of the Oventrop composition pipe "Copipe" and the connection fittings "Cofit S", the Oventrop "Combi-System" makes it possible to complete a whole installation with just one system.

For the radiator connection, Oventrop offers valves, pipes and fittings between boiler and radiators.

The Oventrop composition pipe "Copipe" prevents diffusion of oxygen. In underfloor heating systems it offers safety and is also easy to install. Here, an extensive range of controls and valves is also available.

All components are also suitable for sanitary- and for rain water usage systems.

The system is tested according to the DVGW work sheet W 534 and is registered under the DVGW registration number DW-8501AT2407 for all sizes.

For reasons of technical coordination "Copipe" pipes may only be installed together with the "Cofit" connections and fittings.

2 Composition pipe „Copipe“(DVGW AT2407)

Triple layered composition pipe allowing no oxygen diffusion

- inner pipe layer made of crosslinked polyethylene
- butt welded aluminium sleeve
- outer coating made of crosslinked polyethylene joined with a special bonding agent.

Marking of the pipe: PE-Xc/AL/PE-X

(AL = aluminium, PE-X = crosslinked polyethylene, Xc = electron-beam crosslinked)

Pipe dimensions (outer diameter x wall thickness):

14 x 2 mm, 16 x 2 mm, 20 x 2.5 mm, 26 x 3 mm, 32 x 3 mm

The pipes 16 x 2 mm and 20 x 2.5 mm are also available with insulation. They comply with the requirements of the DIN standard 1988 for the protection of potable water installations (cold) against warming up and development of condensation. The insulation layer is 4 mm thick.

Pressure and temperature limits: 10 bar, 95°C or 16 bar, 20°C.

All dimensions are DVGW approved according to work sheet W 542.

3 Connections and fittings "Cofit S":

3.1 Compression fittings:

3.1.1 For male threaded connection (DVGW AT2407):

For all Oventrop composition pipes "Copipe":
Outlet made of bronze or dezincification-resistant brass reinforced on pipe side with O-ring and PTFE insulation ring for galvanic separation of aluminium and bronze. Tapered metal to metal sealing on opposite side with additional O-ring. Compression ring and collar nut made of brass.

Nickel plated collar nut available for 14, 16 and 20 mm.

3.1.2 For female threaded connection:

For Oventrop composition pipe "Copipe" 14 x 2 mm and 16 x 2 mm:

Outlet made of dezincification-resistant brass reinforced on pipe side with O-ring and PTFE insulation ring for galvanic separation of aluminium and bronze. Metal to metal sealing on opposite side with one edge olive.

Compression ring and compression nut made of brass. Nickel plated compression nut also available.

3.2 Screwed fittings (DVGW AT2407):

Bronze fittings with male thread, metal to metal tapered sealing towards the outlet of the compression fittings. Additional cylindrical surface for O-ring seal.

The fittings serve to connect pipes of the same size, to reduce pipe sizes and to change pipe materials.

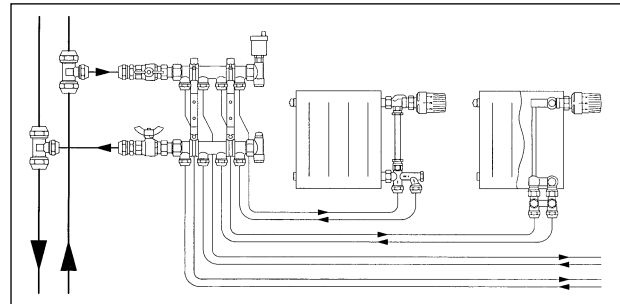

Radiator connection

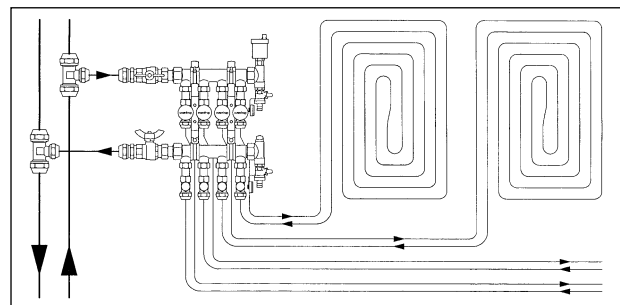

Underfloor heating

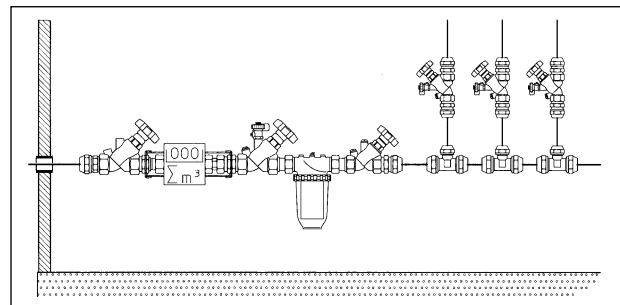

Sanitary installations



Oventrop "Copipe" composition pipe and
Oventrop "Cofit S" connections- and fittings programme

4 Installation tools:

1. Oventrop pipe cutter:

For cutting the Oventrop composition pipes "Copipe" at right angles, one tool for all dimensions. Additional cutting wheel in the grip, further cutting wheels available as spare parts.

2. Oventrop universal tool for deburring and calibrating:

One tool for the pipe dimensions 14 to 32 mm.
For deburring the pipe ends. Prevents damaging of the O-ring of the compression fitting.
Calibrating which is carried out at the same time, ensures that the O-ring will fit perfectly.
Mandrels for replacement are available.

3 Oventrop pipe bending springs:

Prevents breaking and snapping off, specially with hand-made bends having a small radius. Available for the pipe dimensions 14 x 2 mm, 16 x 2 mm and 20 x 2.5 mm, length 600 mm.

4 Oventrop pipe bending tool:

For easy and even bending of pipes, for outer pipe diameters of 14 to 26 mm, mechanical transmission.

5 Oventrop holding key:

For holding the fittings and for an easier installation of the compression fittings.

- spanner size 24/30 for fittings with 3/4" and 1" male thread
- spanner size 36/37 for fittings with 1 1/4" male thread and for tightening the 1" collar nut of the pipe dimension 26 x 3 mm

5 Installation accessories:

1. Oventrop dowel hooks:

To position and fix pipes onto concrete flooring or insulation- and sound absorbing layers.

- single dowel hook up to 32 mm outer diameter
- double dowel hook up to 32 mm outer diameter, advantageous for parallel pipes
- single dowel hook "Maxi" up to 55 mm outer diameter, for fixing the insulation material

2 Oventrop pipe brackets:

For fixing pipes onto the wall, for outer pipe diameter 14, 16 and 20 mm.

3 Oventrop rosette covers:

To cover pipe entry into wall or floor.

4 Protection cap:

To seal wall mounted connection pieces during the pressure test of the cold- and hot water installation according to DIN 1988 and for protection during plastering and tiling.
Cap may only be used once.

6 Installation instructions:

6.1.1 General information:

- For -radiator connection
- underfloor heating
- sanitary installations

Oventrop composition pipe "Copipe" must be insulated according to current regulations and guidelines.
Thermal conductivity of the pipes:

$$\lambda = 0.43 \text{ W/ (m} \cdot \text{K)}$$

Installation of the compression fittings is described under point 8. In case of installation under plaster or in concrete, the fittings must be protected, e.g. by a foil.

6.1.2 Change in length of pipe:

Temperature changes will effect the composition pipe "Copipe" and it will either expand or retract. The slight movements which are to be expected must not be obstructed by the directions or positions of the pipe. To avoid traction on the pipe or bending of the pipe, fixed points must be set in the area where there are connection points.

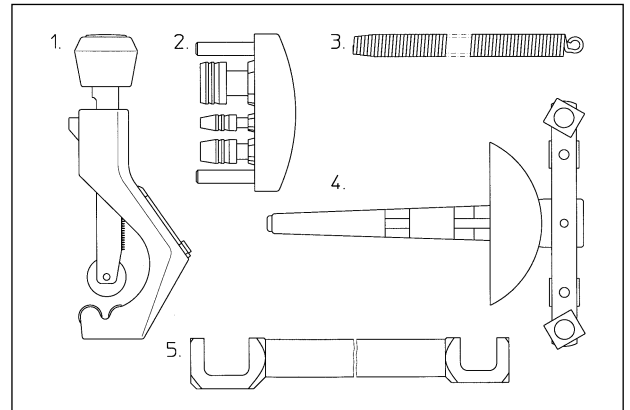

Oventrop installation tools

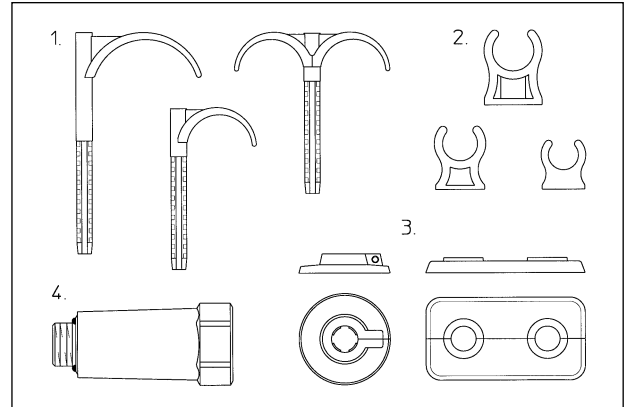

Oventrop installation accessories

Outer pipe diameter x wall thickness $D_a \times s$	Bending by hand ($5 \times D_a$)	Bending by hand with bending spring ($3 \times D_a$)	Bending with Oventrop bending tool
$\varnothing 14 \times 2 \text{ mm}$	70 mm	42 mm	42mm
$\varnothing 16 \times 2 \text{ mm}$	80 mm	48 mm	49 mm
$\varnothing 20 \times 2.5 \text{ mm}$	100 mm	60 mm	79 mm
$\varnothing 26 \times 3 \text{ mm}$			88 mm
$\varnothing 32 \times 3 \text{ mm}$	Installation with elbows		

Table 1: Minimum bending radii for Oventrop composition pipe "Copipe"

Outer pipe diameter D_a	Distance A	
$\varnothing 14 \times 2 \text{ mm}$	1,0 m	
$\varnothing 16 \times 2 \text{ mm}$	1,0 m	
$\varnothing 20 \times 2.5 \text{ mm}$	1,0 m	
$\varnothing 26 \times 3 \text{ mm}$	1,5 m	
$\varnothing 32 \times 3 \text{ mm}$	2,0 m	

Table 2: Distances between fixing points for Oventrop composition pipe "Copipe"

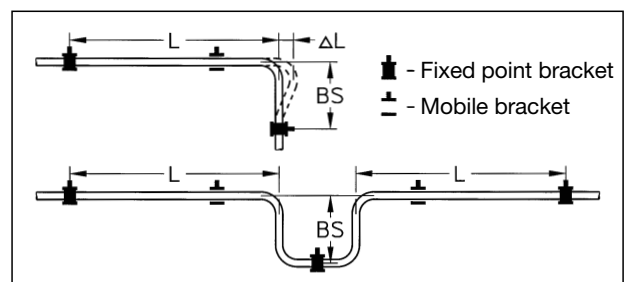

Compensation of changes in length

The linear coefficient of expansion is almost the same as that of copper pipes. Regardless of the pipe dimension it amounts to:

$$\alpha = 0.024 \text{ mm} / (\text{m} \cdot \text{K})$$

The thermal conditional change in length is calculated with the following formula:

$$\Delta L = \alpha \cdot L \cdot \Delta \vartheta$$

	Formula sign	Unit	Values for example
Change in length	ΔL	mm	
Coefficient of expansion	α	mm / (m · K)	0.024
Length of pipe	L	m	5
Difference in temperature	$\Delta \vartheta$	K	60

Example: $\Delta L = 0.024 \text{ mm} / (\text{m} \cdot \text{K}) \cdot 5 \text{ m} \cdot 60 \text{ K}$
 $\Delta L = 7.2 \text{ mm}$

This result is also shown in the chart illustrated under point 10.

This change in length may be compensated by e.g. the insulation material absorbing this expansion. Unhindered expansion is ensured in openly installed pipework by the use of fixed point brackets and mobile brackets, for instance with 90° pipe loops. The minimum length of the loop is calculated by using the following formula:

$$BS = c \cdot \sqrt{(D \cdot \Delta L)}$$

	Formula sign	Unit	Values for examples
Loop length	BS	mm	
Material constant of "Copipe" (= 33)	c	–	33
Outer pipe diameter	D	mm	16
Change in length	ΔL	mm	7.2

Example: $BS = 33 \cdot \sqrt{(16 \text{ mm} \cdot 7.2 \text{ mm})}$
 $BS = 354 \text{ mm}$

This result is also shown in the chart illustrated under point 11.

6.2 Radiator connection:

One- and two pipe systems

6.2.1 Pipework (risers):

For this application, Oventrop offers the composition pipe "Copipe" in dimensions up to 32 x 3 mm as well as the connections- and fittings programme "Cofit S".

Pipes are to be bent and cut according to the indications of the architect or contractor. Oventrop offers the required installation tools. The minimum pipe bending radius can be taken from table 1. Commercial pipe bending tools may be used to bend larger pipe dimensions.

The connection to Oventrop valves and controls is made by means of the appropriate fittings. The installation instructions are to be followed.

Fixing of pipework onto walls and under ceilings can be carried out e.g. by means of standard sound absorbing pipe brackets for plastic pipes. The distances between the fixing points are given in table 2.

6.2.2 Multi storey pipe distribution:

Quick installation of pipework direct of the roll.

The pipe can be bend by hand, by using the bending spring or the bending tool. The pipe must not be kinked. Damaged parts are to be removed.

Work preparation:

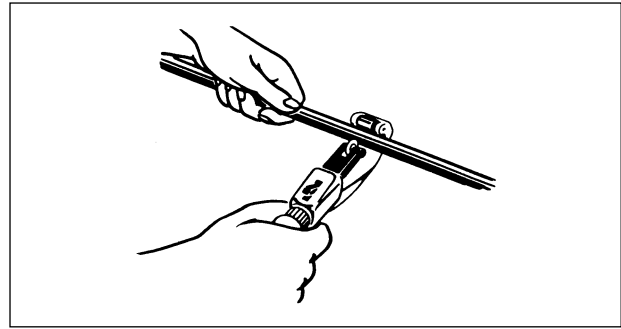

Cut pipe at right angle

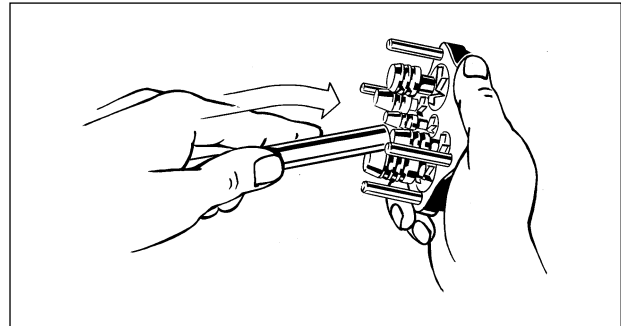

Calibrate pipe

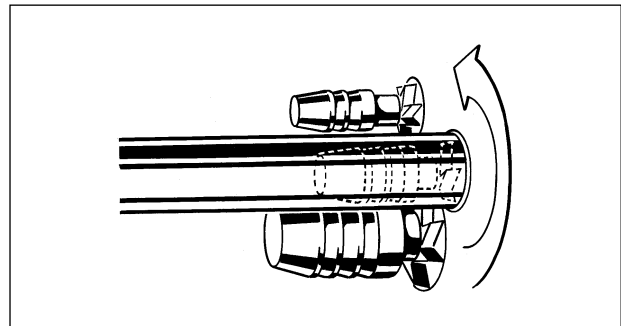

Deburr inner pipe layer

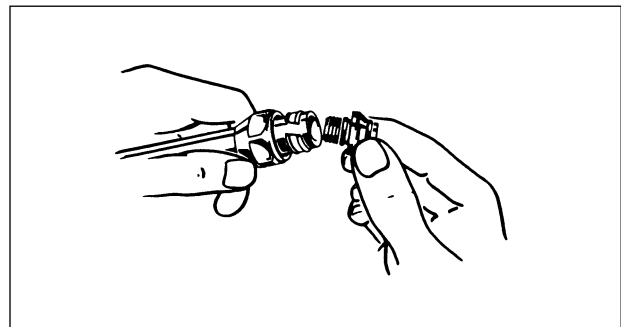

Fit connection

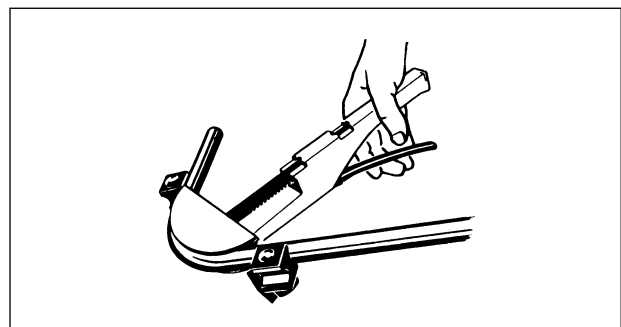

Bend pipe with bending tool

Radiator connection:

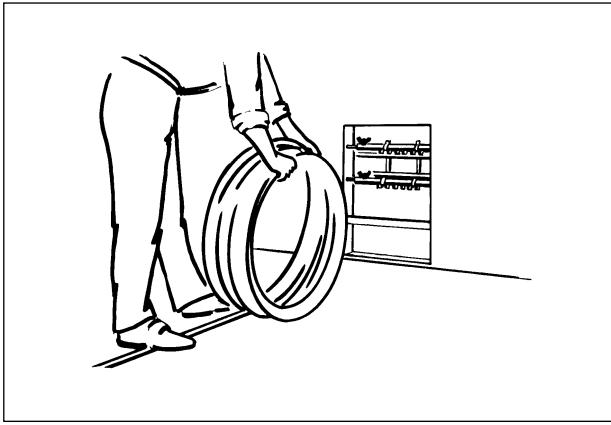

Lay pipe by taking it off the roll

Underfloor heating:

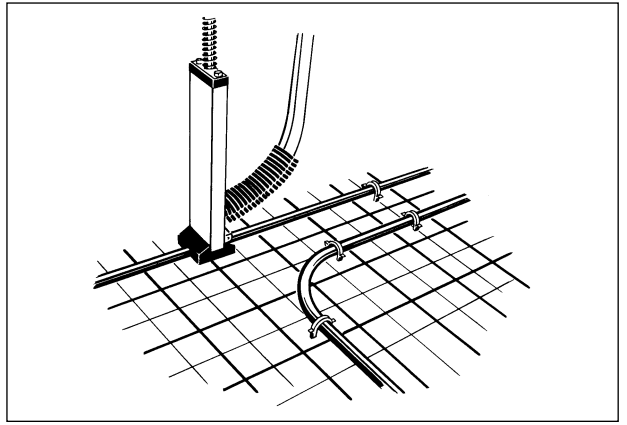

Fix pipe with U-clips and tacker

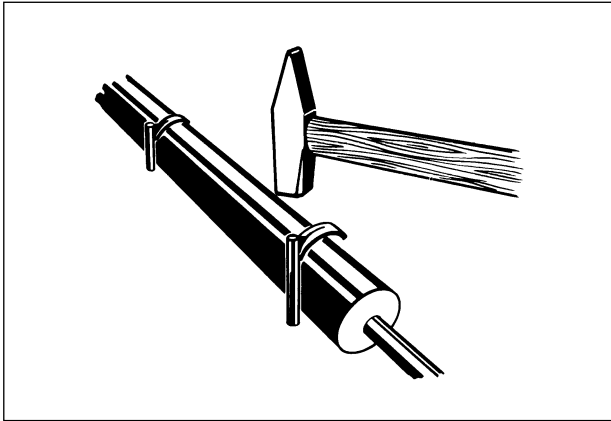

Fix insulated pipes

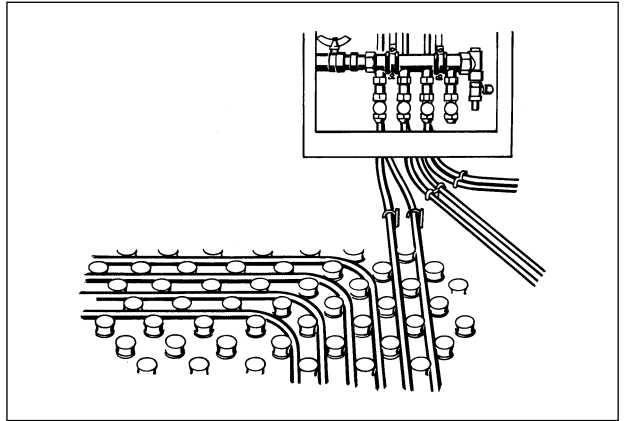

Base mat system

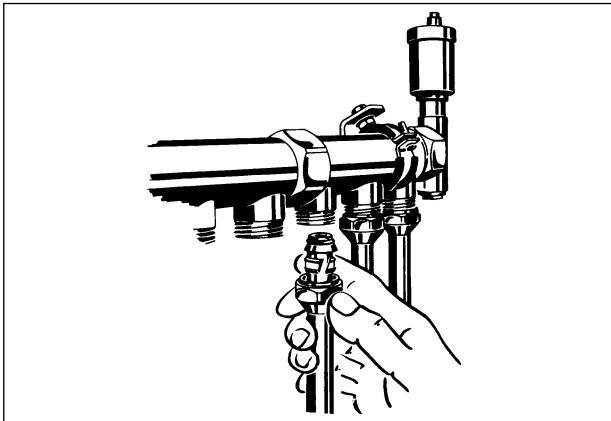

Connect to distributor/collector

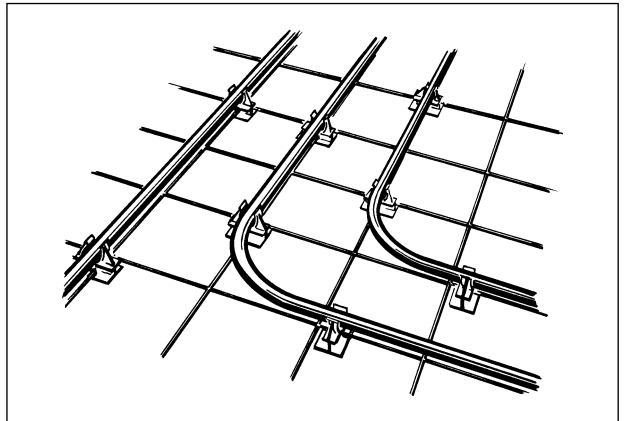

Steel mat system

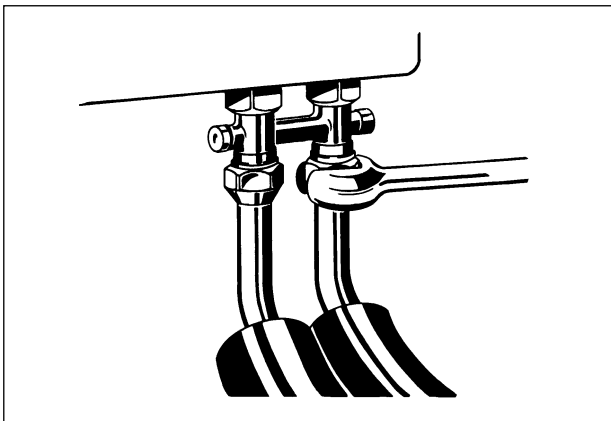

Connect to radiator

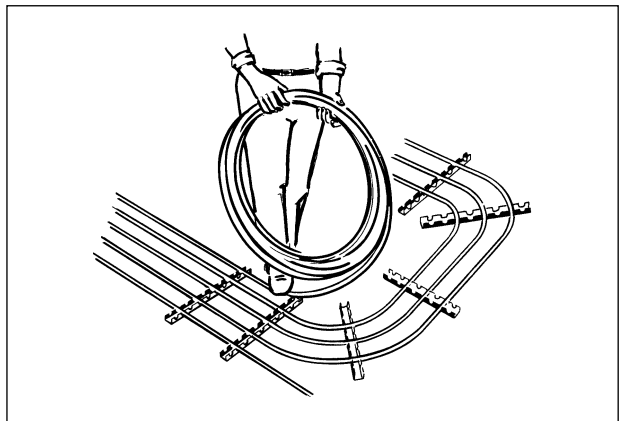

Mounting rails system

Fix pipe onto concrete floor or onto an insulation layer with Oventrop dowel hooks. To do so, drill 8 mm holes and drive the dowels into the floor. Fix pipes onto wall by using the Oventrop pipe brackets. Use a regular pin with M 6 sized thread and screw the pipe bracket onto the wall. Press pipe into the bracket. When installing pipes in horizontal position on plaster, the distances between fixing points as per table 2 are to be observed.

The "Combi-System" allows two principal methods of installation:

- direct connection to centrally located distributor/collector and radiator
- installation with fittings and connection pieces

The Oventrop programme offers valves and controls for the connection of radiators with and without integrated distributor. The variety of connection possibilities can be taken from the technical data sheets.

When connecting pipes to the Oventrop valves by means of compression fittings, the installation instructions have to be followed.

Sanitary installations:

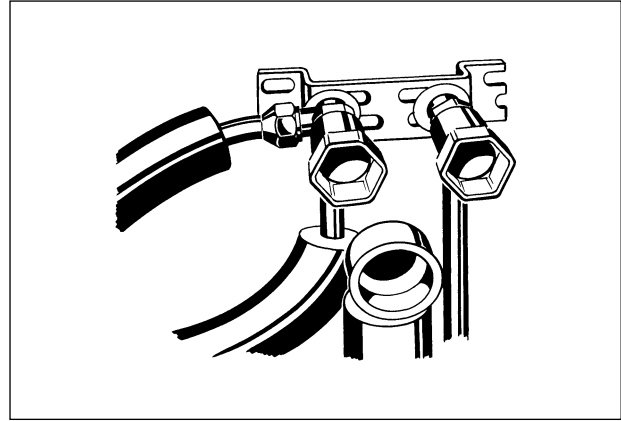

Connection for delivery valves

6.3 Underfloor heating:

6.3.1 Pipework (risers):

Install pipework as described under point 6.2.1

6.3.2 Multi storey pipe distribution:

Installation of pipework from centrally located distributor/collector:

- laying pipes on insulation boards covered with anchoring cloth and foil
- fixing pipes by means of U-clips and tacker
- laying pipes on base mats by pressing pipe into mouldings
- fixing pipes on concrete-steel mats
- laying pipes on mounting rails by pressing pipe into grooves

Further information regarding installation of pipework see point 6.2.2.

When connecting pipes to the Oventrop valves by means of compression fittings, the installation instructions have to be followed.

The Oventrop programme for underfloor heating includes all necessary regulating valves and controls for individual room temperature control.

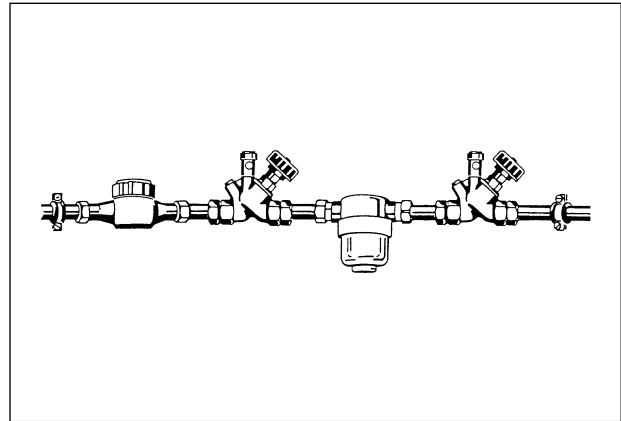

Domestic water connection

6.4 Sanitary installations.

6.4.1 Pipework (risers):

Installation of pipes as described under point 6.2.1. The installation of circulation pipes is possible by using pipes of smaller dimensions.

For the direct connection of the composition pipe "Copipe" to the free-flow and KFR valves "Aquaström", Oventrop offers special valves with enlarged male threads as well as special compression fittings "Cofit S" (DVGW AT2407).

6.4.2 Multi storey pipe distribution:

The "Combi-System" offers the known installation methods:

- installation with straight pattern wall mounted connection pieces. All connection points are near the extraction points
- installation of a ring pipe system. The final valve is connected to the supply pipe again.
- installation of a circulation pipe for hot water supply
- connection of all delivery valves to branch lines, installation by means of fittings and connection pieces

Information regarding installation of pipework see point 6.2.2.

When connecting pipes to the Oventrop valves with compression fittings, the installation instructions have to be followed.

6.4.3 Water content of pipework

The opposite table helps to determine the water content of the pipework.

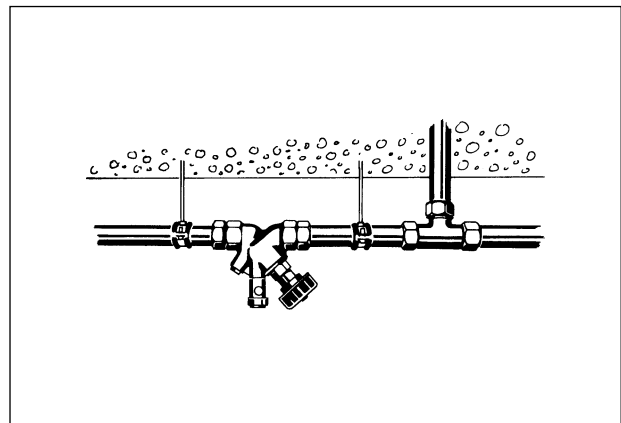

Pipework

Dimension	Size	Inner volume	Weight of pipe
Ø 14 x 2 mm	DN 10	0.079 l/m	104 g/m
Ø 16 x 2 mm	DN 12	0.113 l/m	125 g/m
Ø 20 x 2.5 mm	DN 15	0.177 l/m	185 g/m
Ø 26 x 3 mm	DN 20	0.314 l/m	285 g/m
Ø 32 x 3 mm	DN 25	0.531 l/m	393 g/m

Composition pipe "Copipe" inner volume, weight of pipe

7 Additional information on "Cope" composition pipe:

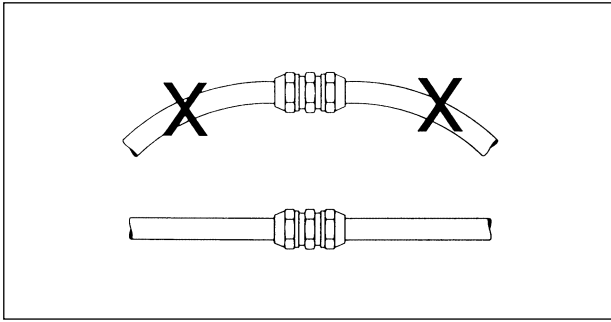

Use only connections and fittings belonging to the system. Install connections and fittings only on straight pipes, never on bends.

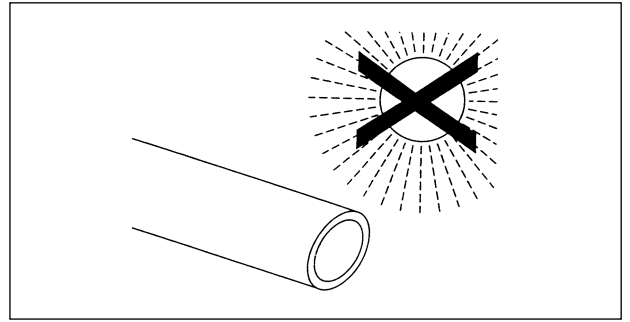

Protect pipe from direct sunlight (UV rays). Do not store in the open without protection.

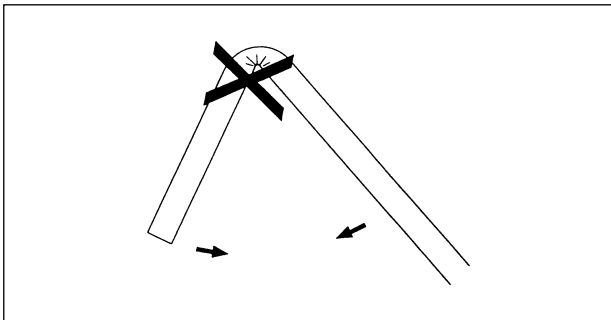

Do not kink/break pipes. Any accidentally kinked parts of the pipe or pipe ends must be removed.

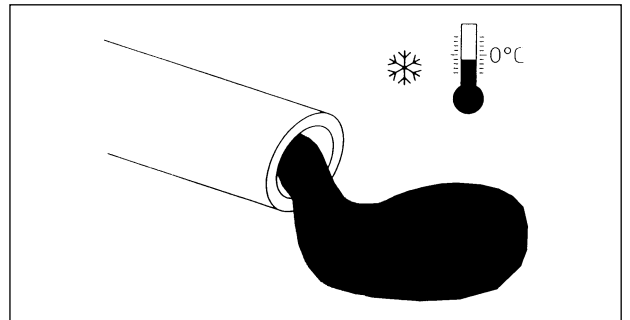

Protect from frost damage by draining pipes or adding a suitable antifreeze liquid to the heating system.

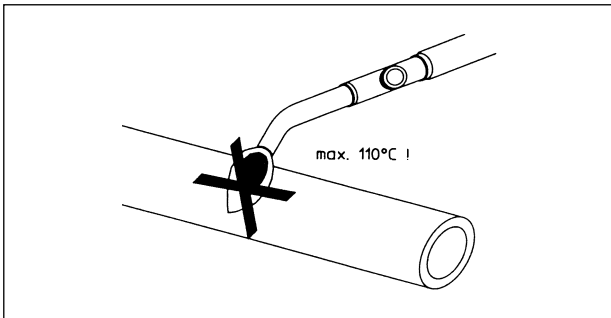

Do not subject pipes to temperatures exceeding 110 °C.

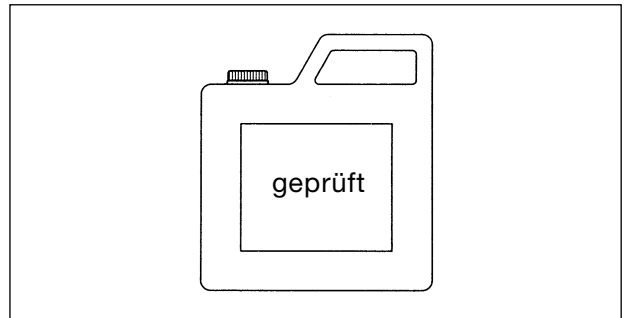

Only use fluids which do not impair the conditions of the pipe. Care must also be taken with additives for heating systems and concrete mixes.

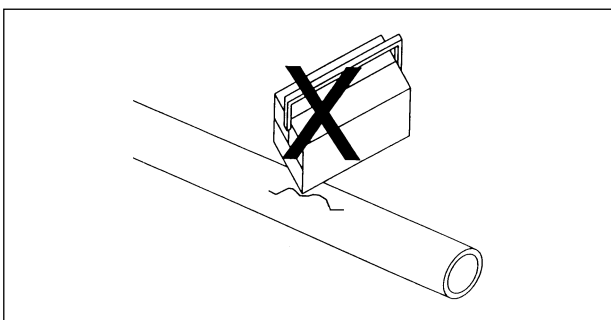

Protect pipes from deformation and mechanical damages.

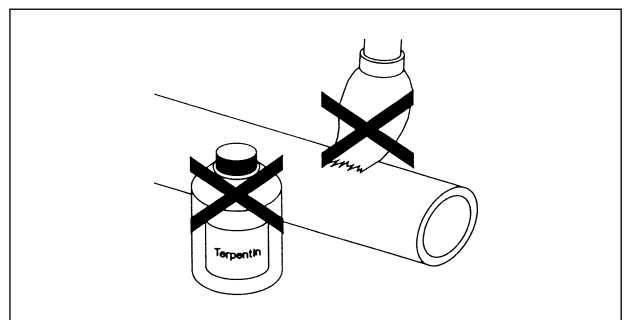

Do not use paints, sprays, pens, cleaning agents, adhesive tape etc. containing solvents on the pipe. When insulating the pipe, use only those materials which will cause no damage to the pipe.

Important:

Follow the instructions of Oventrop and manufacturers of other components, as well as the guidelines, DVGW work sheets and technical rules and regulations.

8 Installation instructions:

Cutting

The "Copipe" composition pipe is cut at a right angle to the required length with a pipe cutter, e.g. Oventrop item no. 150 95 80.

Deburring and calibrating

By using the Oventrop universal tool, item no. 150 95 94, the composition pipe is calibrated and the inner pipe layer is deburred at the same time.

Choose the calibrating and deburring mandrel suitable for the pipe dimension, insert fully into the pipe whilst turning the tool clockwise. Rotate mandrel for at least a further half turn. Remove the tool from the pipe and any shavings will be pulled out automatically. Please observe operating instructions!

Check that the end of the pipe is clean and accurately deburred.

Fit compression fittings for male or female threaded connections as per corresponding drawing.

Care must be taken that the O-rings are not damaged or pushed out of the grooves.

The composition pipe must be pushed completely onto the outlet.

Tighten collar nut or compression nut with appropriate tool.

(14, 16 and 20 mm about 40 - 50 Nm)
(26 and 32 mm about 80 - 90 Nm)

Use compression fittings only once.

Leakage testing

Please ensure that all standard leakage test procedures are carried out.

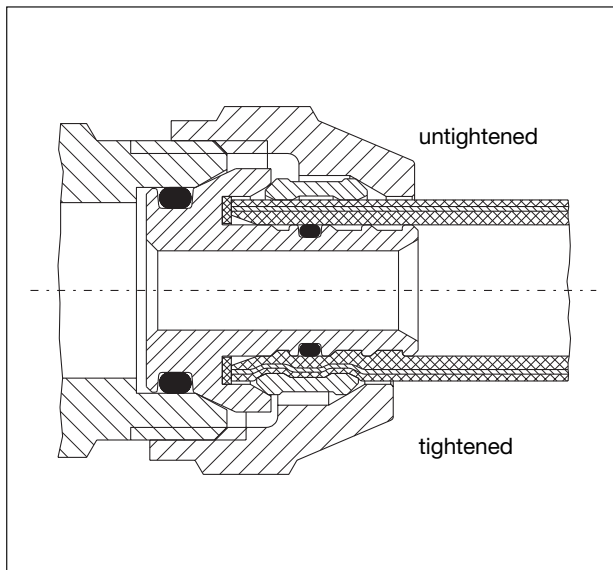

Compression fitting for male threaded connection

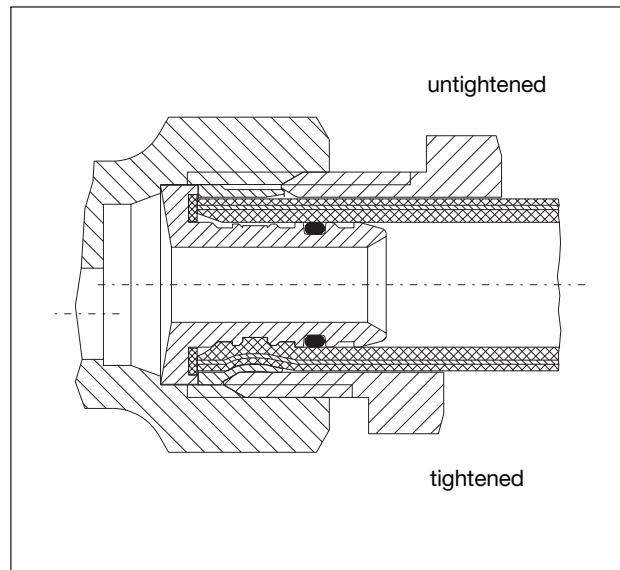

Compression fitting for female threaded connection

9 Pressure loss chart for Oventrop composition pipe "Copipe":

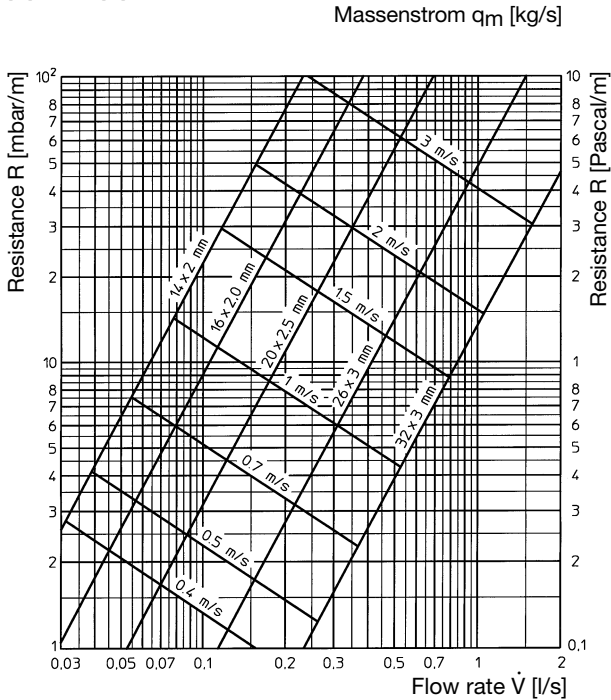

10 Thermal conditional change in length of Oventrop composition pipe "Copipe"

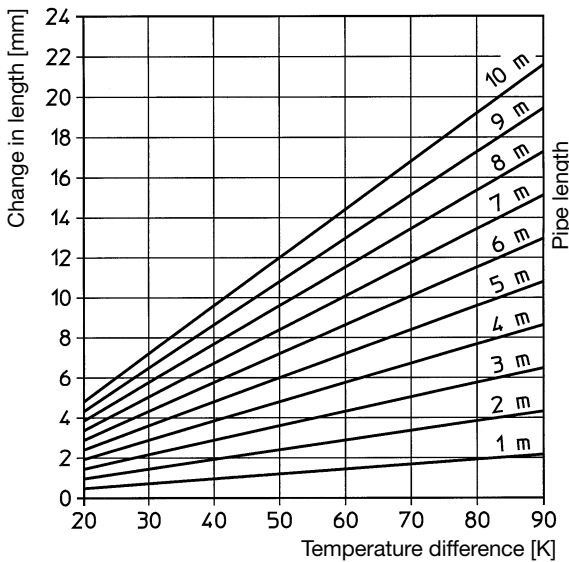

11 Loop chart for Oventrop composition pipe "Copipe"

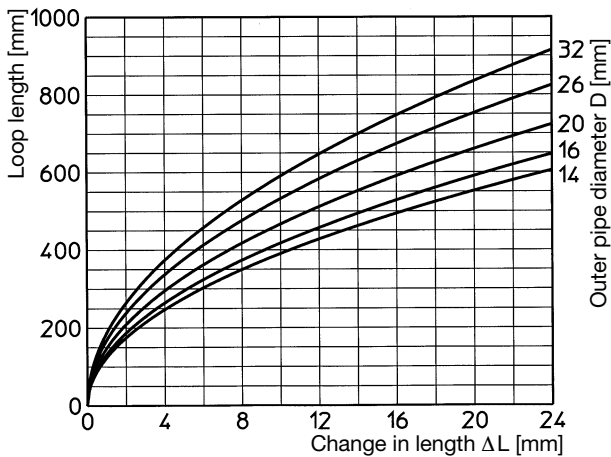

12 Advantages:

- complete system from one supplier
- DVGW system approval (DVGW DW-8501AT2407) for all dimensions
- lasting tightness, thus installation even under plaster and concrete
- same pipe and same fittings programme for these applications:
 - o radiator connection
 - o underfloor heating
 - o sanitary installations
 - o rain water usage
- direct connection to Oventrop free-flow and KRF valves "Aquaström" with enlarged male threads
- considerably reduced storage
- no mistaken identity of pipes and fittings
- high quality composition pipe "Copipe" combines the advantages of metal and plastic pipes
 - o flexibility allows bending by hand, small bending radii (5 x D_a without tool, 3 x D_a with bending spring or bending tool)
 - o no spring back of pipe
 - o no diffusion of oxygen
 - o corrosion resistant, no build up of residues
 - o minimal long term pressure loss
 - o minimal heat expansion (as with metal pipes)
 - o high stability
 - o erosion resistant outer pipe layer
 - o small weight, important with rising pipework
 - o pipe connection without using heat (no welding etc.)
 - o excellent long term durability
- all components of the "Cofit S" programme coming into contact with water are made of high quality bronze
- mixed installation with any pipe material are possible, independent of the direction of flow
- materials may be recycled



DVGW-Reg.-No. DW-8501AT2407



Subject to technical modification without notice.

Product range 14
ti 91-1/10/11.98/MW