

Contents: **A: General**
B: Putting into service (by a technician)
C: How to operate (user)

A: General

A1: Key to symbols and abbreviations

- ... = See. . .
- = Motorised valve drive
- = Thermal valve drive
- = Factory setting
- P/G = Pump or fan
- = Cooling
- T_F = Supply/air intake temperature
- = Please note
- w = Shift
- = 2-pipe system
- = 4-pipe system
- c/o = Change over
- MOD = Control model
- = Heating
- T_R = Room temperature

= When value flashes in the display:-
 (a) it refers to a particular status or
 (b) it denotes a value that can be changed

A2: Keypad

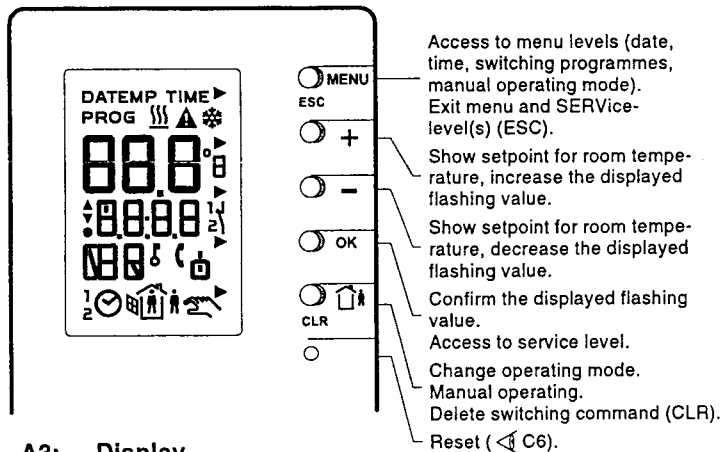

A3: Display

- Button operation active
- Heating mode
- Cooling mode
- Warning/fault notice or MOD 0 selected (< B3, P06)
- Actual value or setpoint for room temperature in °C or °F
- Triac switched through to output, pin 3 or 4
- Relay contact for fan/pump closed
- Time in hours and minutes
- Keypad lock active
- PROG input active
- Value is below dew point
- System off
- Day of week (abbreviated), duration h (hours) or d (days)
- Automatic mode as per weekly (1) or calendar (2) switching programme
- Operating mode
- Manual operating mode

B: Putting into service (by technician)

B1: Make basic setting

After switching the power on for the very first time, you have two minutes in which to enter the language, the time and the date directly.

Select language:

D = German, F = French, E = English, I = Italian
 SP = Spanish, CS = Czech
 1-7 for others (1 = Monday, 2 = Tuesday, ..., 7 = Sunday)

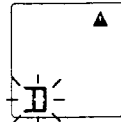

- +, - Select language
- OK Confirm and save the selected language

Enter time and date:

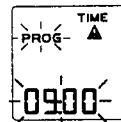

- +, - Set the time
- OK Confirm the time

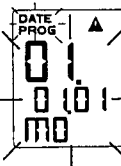

- +, - Set the date
- OK Confirm the Date
- ESC Screen for automatic mode

Select control model:

Select the control model in SERVICE mode (< B2). Adapt the SERVICE parameter P06.

B2: SERVICE mode



Start at the screen automatic mode: -
 Measured room temperature 20,3°C
 Time 09:00
 Day of week: Wednesday
 Operating mode: Occupied

Access to SERVICE mode



- OK >4s (Press button for more than 4 seconds)
- ↑
- OK

View/change SERVICE parameters



- +, - View parameters (- - - denotes unrequired parameters)
- OK List of parameters (< B3)
- +, - Select SERVICE parameters
- OK Change flashing value of parameter
- OK Accept value (or press ESC to abort)



Return to automatic mode

- ESC Return to automatic mode

























B: Putting into service (by technician)

















B3: Extract from list of SERVICE parameters

For a detailed description, see document 7 000986

Nr.:	Explanation
P01:1.xx	View software version
P02:0	View device status (0=OK, >0=fault has occurred)
P03:0	Not used
P04:0	Software reset (0=function not active, 1=Reset SERVICE parameters to  , 2=Reset switching programmes to  , 3=Reset SERVICE parameters and switching programmes to )
P05:0	Manual mode (0=do not enable; >0=enable for % valve position)
P06:0	Control model, see table
P07:0	Language (0=German, 1=French, 2=English 3=Italian, 4=Spanish, 5=Czech, 6=1...7)
P08:0	Unit for the temperature displayed (0=°C, 1=°F)
P09:8	8° minimum limitation of setting range Room temperature setpoint
P10:38	38° maximum limitation of setting range Room temperatre setpoint
P11:0	Measurement of room temperature/dew-point monitoring (0=Room temperature with internal NTC sensor, possibly with additional dew-point monitoring, 1=Room temperature with external Ni1000 sensor 2=Average of room temperature with NTC and Ni1000)
P12:0.0	Influence of wall on room temperature with NTC sensor
P13:0.0	Influence of wall on room temperature with Ni1000 sensor
P14:1	Input function w - c/o (0=not active, 1=c/o signal, 2=c/o signal with coling block, 3=w with 1K/V extra, change jumper over 4=w with 1,6K/V extra, change jumper over
P15:0	PROG input function (see diagram)
P16:0	Direction of operation for PROG input (0=active closed, 1=active open)
P17:2.0	2K proportional band of the P controller with MOD 3...8
P18:4	4 minutes period duration for the P controller with MOD 3,4,7
P19:10	10% min. switch-on time for the P controller with MOD 3,4,7
P20:40	40K proportional band of the PI controller with MOD 1,2,5,6,8
P21:240	240 sec. reset time for the PI controller with MOD 1,2,5,6,8
P22:120	120 sec. valve running time with MOD 1,2,5,6,8
P23:10	10°C minimum limitation of supply/air intake temperature with MOD 5,6,8
P24:50	50°C maximum limitation of supply/air intake temperature with MOD 5,6,8
P25:1.0	1.0K neutral zone for "occupied" operating mode
P26:10.0	10.0K neutral zone for "unoccupied" operating mode
P27:0	"unoccupied" operating mode allowed for (0=heating and cooling, 1=heating only, 2=cooling only)
P28:1	Frost protection (F) and overheating protection (U) (0=not active, 1=F active, 2=U active, 3=F+U active)
P29:3	Function of relay output (0=no function, 1=pump/fan for heating, 2=pump/fan for cooling, 3=pump/fan for heating and cooling, 4=pilot timer controlled by weekly and calendar switching program 5=as 4, also taking account of change in operation mode (< C3) 6=as 5, taking account of PROG input 7=heating/cooling output, open contact equals heating in this case)
P30:0	Anti-jamming function for valves and pumps or fans (0=not active, 1=active for valve, 2=active for pump or fan, 3=active for valve and pump or fan)
P31:0	View total duration of closed relay
P32:0	Calendar programme (0=not active, 1=active)
P33:10.25	25th October: summer-winter time change
P34:03.25	25th March: winter-summer time change
P35:42.3	View actual value for supply/air intake temperature
P36:43.7	View setpoint for supply/air intake temperature
P37:3	3K View setpoint for shift w

SERVICE parameter P06 (value of parameter = MOD)

Param.: value	Plant	Application	Control behaviour	Triac outputs
P06:0; 	-	-	-	Voltage-free
P06:1			PI	
P06:2			PI	
P06:3			P	
P06:4			P	
P06:5			P+PI	
P06:6			P+PI	
P06:7			P	
P06:8			P+PI	

Param.: value	Function of the switch input	Display when contacts active
 P15:000	Unoccupied	 
P15:001	Occupied	 
P15:002	Window contact	 
P15:003	Remote switching	 
P15:004	Fault signal	 
P15:005	Keypad disabled	 
P15:006	c/o	 
P15:007	c/o with cooling block	 

Function of PROG input:

When a contact is active, it generally interrupts the automatic mode if the SERVICE parameter has a value of 0, 1, 2 or 3. A change of operating mode as described in section C3 takes precedence.

B4: Manual mode

Fistly, enable mode in SERVICE mode (< B2). In manual mode, **no regulation** takes place. The pump is switched on or off. The valve opening is permanently set.

Access to manual mode



- MENU Call up the menu
- (1 x) Browse through the menu
- OK Select the "Manual mode" menu item

Set the status of the pump/fan (ON/OFF) for manual mode





- OK Select the "Pump/fan relay" sub-item from the menu
- +, - Change the flashing value " | " (pump/fan off) or " 0 " (pump/fan on) and confirm
- OK

Note: with MOD8, two valves are operated by the signal.

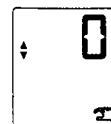
Set the valve position



- + Browse through the menu
- OK Select the "Valve opening" sub-item from the menu
- +, - Change the flashing value for the valve opening (in %)
- OK and confirm

Note: with MOD7, the valves for heating (display ) and cooling (display ) can be operated independently of one another, but not at the same time.

(De-) activate manual mode

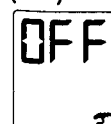

- + Browse through the "Manual mode" menu
- OK Select the (De-) activate manual mode' sub-item from the menu
- +, - Change the flashing value " 00 " (manual mode on) or " OFF " (manual mode off)
- OK and confirm

Return to automatic/manual mode

- (2 x) Return to manual or automatic mode
- ESC

B: Putting into operation (by technician)

B5: Examples for various applications

Note:

The values for the proportional band and the reset time that are shown in the examples have been tried and tested, but they are not necessarily the best solutions for every plant.

B5.1: Example for MOD 2

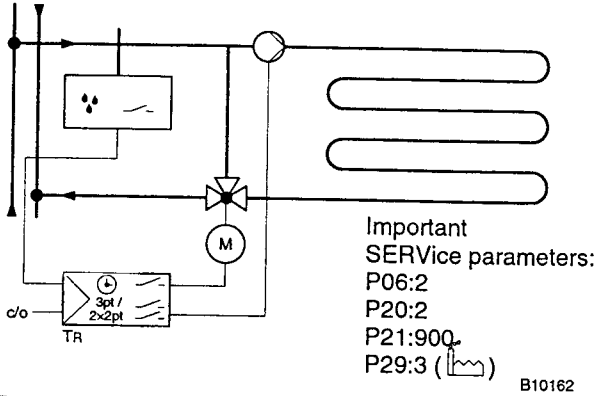

Floor heating/cooling with dew-point monitoring and c/o input

B5.3: Example for MOD 5

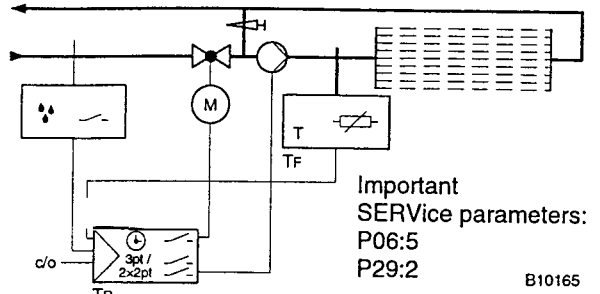

Cascading cooling ceiling control with dew-point monitoring and c/o input

B5.2: Examples for MOD 4

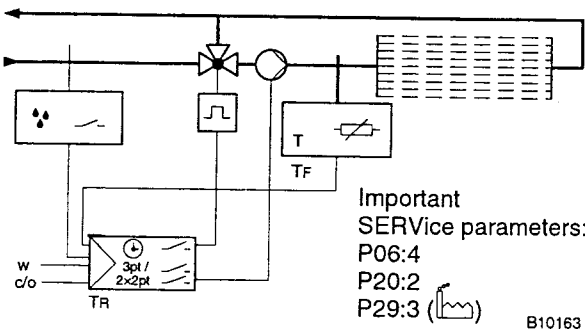

Cooling ceiling control with shift in room temperature setpoint and c/o input

B5.4: Example for MOD 6

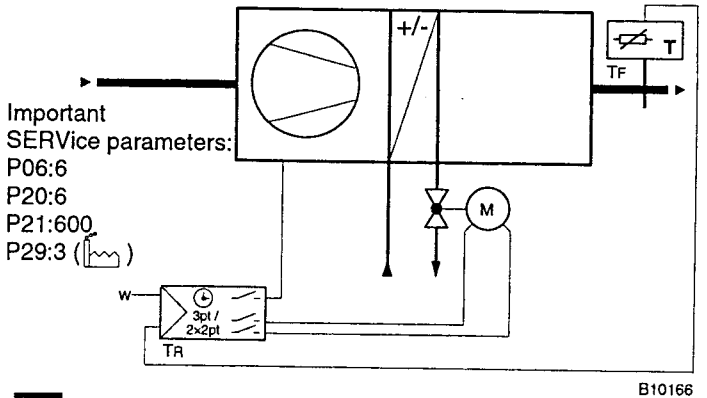

Cascading room air/air intake control for heating/cooling with shift in room temperature setpoint

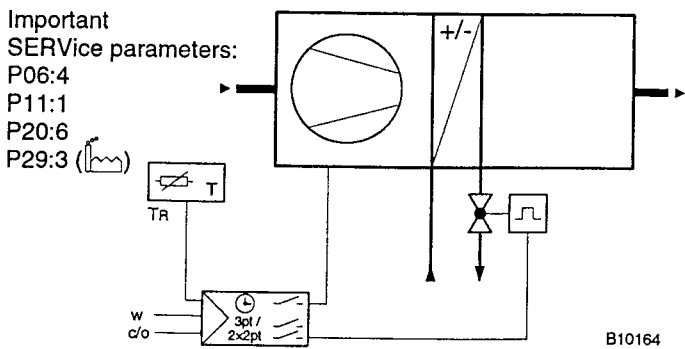

Ventilation system for room temperature control, heating/cooling with external temperature sensor, shift in room temperature setpoint and c/o input

B5.5: Example for MOD 7

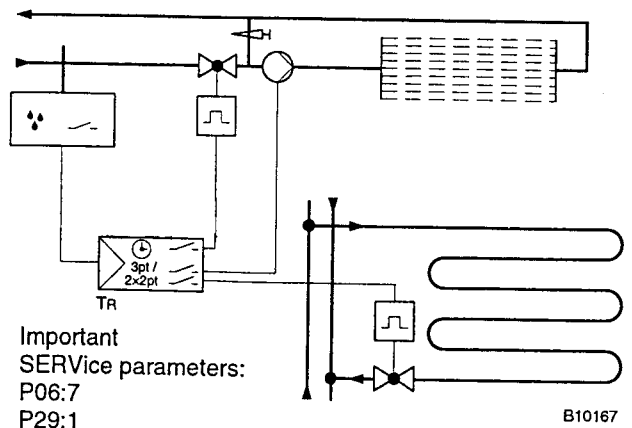

Cooling ceiling control and floor heating with dew-point monitoring

C: How to operate (by user)

All the entries described below assume that the device is in automatic mode (1☑)

C1: Change date and time

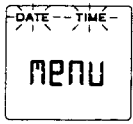

- MENU Call up the menu
- OK Select the "Date Time" menu item
- +, - Change the flashing value for **Time** and confirm
- OK
- +, - Change the flashing value for **Date** and confirm
- OK
- ESC Exit the menu

C2: Change temperature setpoint

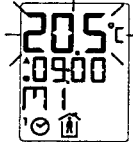

- +, - Change the temperature setpoint and confirm
- OK

Comment:

After you have confirmed the new setpoint, the display will show the current actual value again

C3: (Un)limited change of operating mode



- Call up the function
- Select the operating mode: "Occupied" (), "Unoccupied" () or Plant Off ()

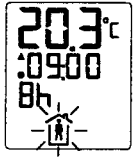

- +, - Enter the duration of the change from limited 19 days (d) to 3 hours (h) or unlimited (-d) or temporary (t) until the next switching point (minimum 2 hours)
- OK and confirm

Comment:

Use ESC to cancel the temperature change and return to operation by switching programme

C4: Weekly switching programme

The weekly switching programme repeats itself every week. It comprises a maximum of 42 switching commands with their associated modes. These commands are captive.

- MENU Call up the menu
- + (1x) Browse through the menu
- OK Select the "1☑" menu item and view the first switching command
- +, - View next (+) or previous (-) switching command (a spare command is shown as _ _ : _ _)

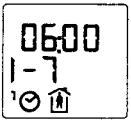

Delete switching command

- CLR >4s Delete switching command (To erase all switching commands, press the button for >10 seconds)

C4: Weekly switching programme (continued)



Change switching command

- OK Change the displayed switching command or enter a new one
- +, - Enter the flashing **Day** value or change it and confirm
- OK
- +, - Enter the flashing **Time** value or change it and confirm
- OK
- Select the flashing **Operating mode** value, Occupied () , Unoccupied () or Plant Off () and confirm, and return to view switching commands
- OK

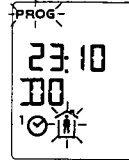

Return to automatic mode

- ESC Return to the "1☑" menu item
- ESC Return to automatic mode

Notes on the weekly switching programme

- A switching command can apply daily (1-7) or on a certain day (Mon, Tue, etc.).
- If there is a switching command on a certain weekday (Mon, Tue, etc.) the daily command (1-7) does not apply on that day.
- "End" denotes that the memory is full.

For the calendar switching programme, see document 7000986

Factory setting for the weekly switching programme

Mon...Thu	from 06:00h:	from 22:00h:
Fri	from 06:00h:	from 22:30h:
Sat	from 07:00h:	from 23:00h:
Sun	from 07:00h:	from 22:00h:

C5: Keypad lock

Look the keypad by pressing the following sequence of buttons:



- OK Use the same sequence of buttons to unlock the keys
- +
-
-

C6: Reset

The controller can be reset by pressing the reset button (◀ A2). Then re-enter the time and date. The SERVICE parameters and the switching program are unaffected.

C7: Technical data

Dimensions	(BxHxT): 76x152x36mm	Ambient temperature:	0...50 °C
Supply:	24V~	Ambient humidity:	0...95 r.F.
Tolerance:	+/- 15%; 50...60Hz	Storage temperature:	-25...65°C
Power consumption:	<1,5VA	Conforms to:	EN12098 und CE
Outputs:	1 relay, 2 Triac	Type of protection:	IP30 (EN60529)
Switching power:	Triac 0,3 [0,5] A	Protection class:	II (IEC536)
	Relay 5 (2) A	EMC radiation:	EN50081-1
Inputs:	1binary, 3 analogues	EMC Immunity:	EN50082-2
Switch clock:	Power reserve > 6h	Level of radio suppression:	EN55014 and EN55022
Parameters:	non-volatile	Safety:	EN60730-1