

⚠ Before installing the wireless room control unit “RBG-C F” (item no. 1153050) as well as its accessory components, please read and follow the installation instructions and operating manual in full!
Installation, commissioning, operation and maintenance must only be performed by trained and specialised staff in compliance with applicable rules and regulations!
The installation instructions, the operating manual for the respective “DynaTemp” system as well as all additionally applicable documentation must be forwarded to the system operator!

Content

1	General information	1
2	Safety instructions	2
3	Transport, storage and packaging	2
4	Technical specifications	2
5	Dimensions	2
6	Configuration and function	3
7	Assembly and installation	3
8	Commissioning	3
9	Information about radio	4
10	Teaching in and deleting	5
11	Accessories	5
12	Maintenance and servicing	5
13	Declaration of conformity	5
14	Warranty	5



Fig. 1.1 Wireless room control unit “RBG-C F”, solar-powered

1 General information

1.1 Information about the installation and operating instructions

These installation instructions are to be used by the trained and specialised staff to properly install, commission and configure the wireless room control unit “RBG-C F” for the first time. Following installation, additional documentation like for example the operating manual for the associated system “DynaTemp” is to be downloaded from the control and regulation unit (DDC) in the “**HELP/INFO - Documentation**” menu item with an Internet browser, e.g. “Mozilla Firefox”.

Additionally applicable documentation - instructions for all system components as well as applicable technical rules - are to be complied with.

1.2 Safekeeping of documentation

These installation instructions are to be stored in a safe place by the system operator for later use.

1.3 Symbol explanation

Safety guidelines are displayed by symbols. These guidelines are to be observed to prevent accidents, damage to property and malfunctions.

⚠ DANGER DANGER indicates a hazardous situation which, if not avoided, will result in death or serious injury.

⚠ WARNING WARNING indicates a hazardous situation which, if not avoided, could result in death or serious injury.

⚠ CAUTION CAUTION indicates a hazardous situation which, if not avoided, may result in minor or moderate injury.

NOTICE NOTICE indicates a situation which, if not addressed, may result in property damage.

1.4 Copyright

These installation instructions are protected by copyright. Usage of the control and regulation unit with its accessory components is subject to a license. The license text can be found on the control and regulation unit in the “**HELP/INFO - Documentation**” menu item. By using the product you agree to the license agreement.

OVENTROP GmbH & Co. KG
 Paul-Oventrop-Straße 1
 59939 Olsberg
 Deutschland
 Phone +49 (0) 29 62 82-0
 Fax +49 (0) 29 62 82-400
 E-mail mail@oventrop.de
 Internet www.oventrop.com

For an overview of our global presence
 visit www.oventrop.com.

Subject to technical modification without notice.
 115305081 09/2019

2 Safety instructions

2.1 Intended use

The solar-powered wireless room control unit is used for temperature control in connection with the receiver interfaces SRC-x and the superordinated "DynaTemp" control and regulation unit. Transmission occurs via radio telegrams according to EnOcean standard to the recipient (radio-based room module). Following a successful teach-in process, the room temperature can be adapted via temperature controller and occupancy button.

Operational safety can only be ensured for intended use of the associated "DynaTemp" control and regulation unit and its accessories.

Any additional and/or other usage of the room control unit "RBG-C F" is prohibited and is considered as contrary to intended use. Any claims against the manufacturer and/or his authorised representatives for damages as a result of non-intended use cannot be recognised. The intended use also includes proper compliance with the installation instructions.

The content of these installation instructions is solely intended for the transmission of information.

2.2 High-frequency emissions of radio sensors

Since the advent of cordless telephones and the usage of radio systems in residential buildings, the influencing factors of the radio waves on the health of people living and working in these buildings have been widely debated. Often there is great uncertainty amongst supporters as well as critics due to a lack of measurement results and long-term studies. A measurement certificate from the Institute for Socio-Ecological Research and Education (ECOLOG) has now confirmed that the high-frequency emissions of radio-controlled switches and sensors with EnOcean technology are significantly lower than comparable conventional switches. What needs to be known is that conventional switches also emit electromagnetic fields due to the contact spark. The radiated power flux density (W/m^2) is 100 times higher than for radio-controlled switches, observed across the total frequency range. In addition, due to reduced cabling for radio-controlled switches, potential exposure to low-frequency magnetic fields emitted via cables is decreased.

2.3 Risks posed by the place of installation and transport

The possibility of an external fire was not considered when designing the control and regulation unit and its accessories.

⚠ WARNING

Risk of injury

Hot or cold surfaces!

Risk of injury! Only touch with suitable protective gloves. During operation, the radiator valve can get as hot as the medium.

Sharp edges!

Risk of injury! Only touch with suitable protective gloves.

Threads, holes and edges are sharp-edged.

Small parts!

Risk of accidental swallowing! Do not store and install room control units "RBG-C F" and their accessories within the reach of children.

Allergies!

Health hazard! Do not touch items and avoid any contact if allergies to materials used are known.

3 Transport, storage and packaging

3.1 Transport inspection

Check consignment for completeness and any transport damage immediately after receipt and before installation.

If such or other defects are found, only accept the consignment with reservation. File a complaint. Observe complaint deadlines in doing so.

3.2 Storage

Only store the room control units "RBG-C F" under the following conditions:

- Store indoors in dry and dust-free conditions.
- Do not expose to aggressive media or heat sources.
- Protect from solar radiation and excessive mechanical vibrations.
- Storage temperature: $-10^{\circ}C \dots +65^{\circ}C$
- Relative humidity (r.h.): 10 ...95 %, non-condensing

3.3 Packaging

All packaging material is to be disposed of in an environmentally sound manner. Please do not let your children play with any packaging materials – they could be a danger to them.

4 Technical specifications

General

Technology:	EnOcean, STM
Transmit frequency:	868.3MHz
Range:	approx. 30 metres buildings, approx. 300m open air
Temperature sensor:	Range $0^{\circ}C \dots +40^{\circ}C$, Resolution 0.15K Abs. accuracy typ. +/-0.4K
Data logging:	every 100 seconds
Transmission interval:	every 100 seconds in case of changes $>0.8K$ or $>5^{\circ}$ rotation angle or actuation of the switch or every 1000 seconds in case of changes $<0.8K$ and $<5^{\circ}$ rotation angle
Energy generator:	Solar cell, internal Goldcap, maintenance-free
Housing:	ABS (ASA), white similar to RAL 9010
Protection type:	IP30 in accordance with EN60529
Ambient temperature:	$-25 \dots +65^{\circ}C$
Weight:	50g
Nominal value logging P:	Range: $0 \dots 270^{\circ}$ rotation angle
Resolution:	1.1°
Switch T:	Closing contact

5 Dimensions

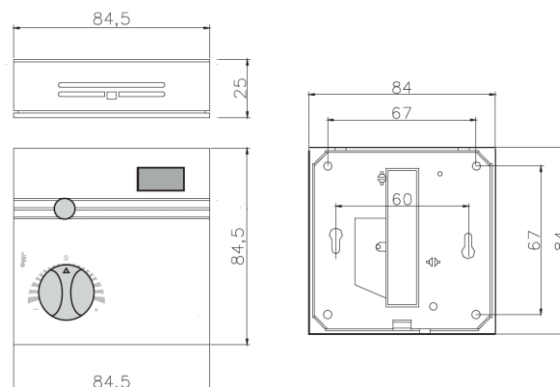

6 Configuration and function

6.1 General installation instructions

When choosing the installation site, the following specifications with regard to correct and sufficient ambient lighting are to be adhered to. By using the energy-optimised radio technology EnOcean in the "EasySens" radio sensors, which supply themselves with electrical energy with a 2cm² large solar cell, the units can work without batteries. As replaceable batteries are no longer needed, the units are practically maintenance-free and environmentally friendly. If required, in case of prolonged storage of the radio sensors in darkness, the solar-powered energy store must be recharged, e.g. during commissioning. This normally occurs automatically during the first few hours of operation in daylight. If the initial charge during the first hours of operation should not be sufficient, the sensor will achieve full operational readiness after 3 or 4 days at the latest. After this period at the latest the sensor will also transmit in the dark (at night) without any problems.

When choosing the installation site the following points should be considered:

- The minimum level of illumination of 150 lx should be available at the installation site for at least 3-4 hours - independent of whether this is artificial or natural light. For comparison: Workplace regulations specify a minimum level of illumination for office workplaces of 500lx.
- The level of illumination should not be more than 1000lx for prolonged periods.
- Room niches not sufficiently illuminated during the course of the day should be avoided.
- When using bundled artificial light, the incidence angle onto the solar cell should not be too steep.
- The sensor is to be preferably installed with solar cell side towards the window, direct sunlight is to be avoided here. Temporary direct solar radiation would lead to incorrect readings when measuring the temperature.
- The installation site should also be chosen with regard to later usage of the room, so that shading by the users, e.g. through storage shelves or rolling cabinets, is avoided.

6.2 Ambient lighting too low

Depending on the application (dark rooms etc.), the unit can also be operated with a battery. The sensor is prepared with a respective battery holder. Battery to be used: Lithium battery 3.6V / 1.1Ah type LS14250 / 1/2 AA, operating time in case of battery operation approx. 5 - 10 years, depending on the ageing and self-discharge of the battery used. In order to switch the sensor from solar to battery operation, simply insert the battery into the holder.

1. Open the base part

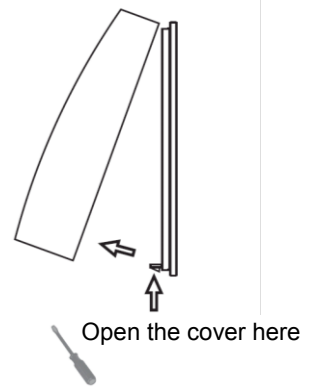

2. Insert the battery into the holder

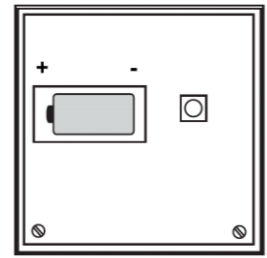

7 Assembly and installation

7.1 Assembly instructions

Assembly of the sensor occurs by adhering the sensor base plate with the supplied adhesive tape to the level wall surface. If required, the plate can also be attached with dowel and screws. The cover is then attached to the base plate. The sensor is supplied ready for operation. If required, in case of prolonged storage of the radio sensors in darkness, the internal solar-powered energy store must be recharged. This normally occurs automatically during the first few hours of operation in daylight. Please refer to notes on "Solar energy store".

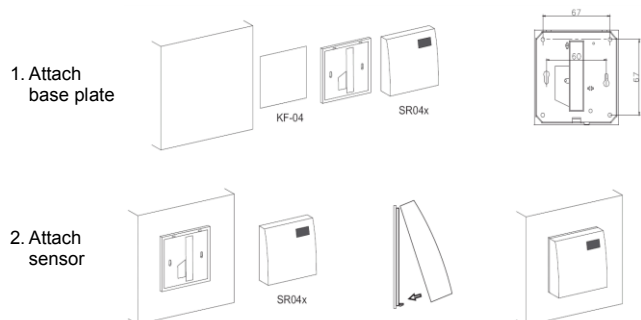

8 Commissioning

After delivery the room operating unit might be in default shipping mode, in this case press the learn button (<1 second) at the rear of the device.

The sensor is supplied in an operational status. Probably, the internal solar energy storage must be recharged after a longer storage of the radio sensors in darkness. Basically, the recharging process is done automatically during the first operating hours in daylight.

To ensure correct evaluation of the sensor's readings on the receiver, it is necessary to program the units into the receiver (radio-based room module). This can only be performed via the respective "DynaTemp" operating program and occurs automatically with the "**Learn button**" on the sensor or manually in the so-called "**Offline mode**" by entering the 32 bit sensor ID (barcode). Details are described in the respective operating manual.

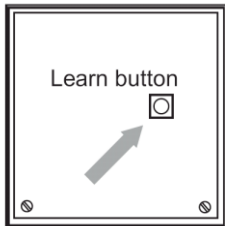

Teach-in telegram when button is pressed

CAUTION

The unit must only be installed in dry rooms that are not subject to explosion hazards.

9 Information about radio

9.1 Coverage planning

As the radio signals are electromagnetic waves, the signal on its way from sender to receiver is attenuated. This means that the electrical as well as magnetic field strength decreases, namely inversely proportional to the square of the distance of sender and receiver ($E, H \sim 1/r^2$). Apart from this natural coverage limitation, there are additional interference factors: Metallic parts, e.g. armouring in walls, metal foil of heat insulation or metallised heat protection glass all reflect electromagnetic waves. This results in a so-called radio shadow being formed behind. Radio waves might be able to get through walls, but this increases the attenuation even more than during propagation in open air.

9.2 Permeation of radio signals:

- Wood, plaster, uncoated glass 90...100%
- Brickwork, pressboard 65...95%
- Armoured concrete 10...90%
- Metal, aluminium lamination 0...10%

In practice, this means that the building materials used in buildings play an important role when assessing the radio range. Some reference values so that the surrounding area can be assessed: Transmission path range/permeation:

9.3 Visual contacts:

- Typ. 30m range in corridors
- Up to 100m in halls
- Plasterboard walls/wood: Typ. 30m range through max. 5 walls
- Brick wall/aerated concrete: Typ. 20m range through max. 3 walls
- Armoured concrete walls/ceilings: Typ. 10m range through max. 1 ceiling

Supply blocks and elevator shafts should be regarded as sealing-off. Furthermore, the angle at which the sent signal hits the wall plays a role. Depending on the angle, the effective wall strength and thus attenuation of the signal changes. If possible, the signals should run vertically through the masonry. Niches in walls are to be avoided. Devices that also operate with high-frequency signals, e.g. computers, audio/video systems, electronic transformers and ballasts count as additional disturbance

sources. The minimum distance to these devices should be 0.5m.

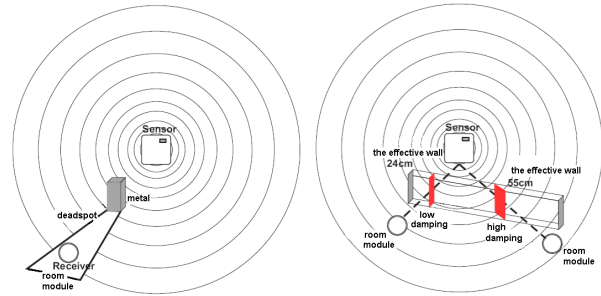

9.4 Sending frequency

The sensors send radio telegrams to the receiver event- or time-controlled.

9.5 Measuring principle and telegram generation

9.5.1 A: "event-controlled"

By pressing the learn button of the unit, the internal microprocessor is activated, the measured value for temperature is determined and a telegram to the receiver is generated.

9.5.2 B: "time-controlled"

The internal microprocessor is activated at a time interval of approx. 1.6 minutes ($T_{wake\ up}$), and the measured value for the temperature is determined. If the status of an input has changed since the last request (temperature change $> 2\%$ ($> 0.8^\circ C$)), a telegram is generated instantly. If the temperature remains unchanged compared to the previous telegram, a telegram is generated automatically once the fixed transmission time expires after approx. 16 minutes (T_{send}). Once a telegram is sent, whether it is generated through a change of state or expiry of T_{send} , the timers for $T_{wake\ up}$ and $T_{interval}$ are restarted.

Note: A telegram always includes all information (temperature value etc....)

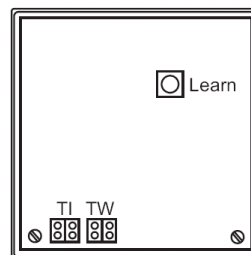

TI (Tinterval)	TW (Twake up)
=1	=1
=10	=10
=100	=100

9.6 Factory settings

$T_{wake\ up}$: 100, $T_{interval}$: 10
 $T_{send} = 100\ sec.\ wake\ up \times 10\ interval = 1000\ Seconds =$
 approx. 16 minutes

Notes:

The sending frequency also has a direct impact on the operating energy available in the energy store and thus on the discharge time of the energy store during operation. If the ambient lighting is too low, it might be necessary to operate the unit with a lithium battery 3.6 V/1.1 Ah, type: LS14250 / 1/2 AA.

9.7 Description radio telegram

ORG	always 7 dec. (EnOcean unit type "4BS")
Data_byte3	Fan levels LevelAuto = n>210 Level 0 = 190<n<210 Level 1 = 165<n<190 Level 2 = 145<n<165 Level 3 = n<145
Data_byte2	Nominal value min. -...max. +, linear n=0...255
Data_byte1	Temperature 0...40°C, linear n=255...0
Data_byte0	Bit D3 learn button (0=switch actuated) Bit D0 occupancy button (0=switch actuated) or slide switch 0/1 (1= position 0)
ID_Byte3	Unit ID (Byte3)
ID_Byte2	Unit ID (Byte2)
ID_Byte1	Unit ID (Byte1)
ID_Byte0	Unit ID (Byte0)
EnOcean profile	
SR04:	ORG07 FUNC02 TYPE05 („RS-C F“)
SR04 PT:	ORG07 FUNC10 TYPE05 („RBG-C F“)
SR04 PST:	ORG07 FUNC10 TYPE01

10 Teaching in and deleting

10.1 Teach in process to the radio room module

The room assignment for a unit (**teach in process**) is only possible via the respective "DynaTemp" operating program (see operating manual).

10.2 Deleting via the "DynaTemp" operating program

Please follow the instructions of the operating program.

11 Accessories

See operating manual.

12 Maintenance and servicing

The product is maintenance-free. A repair must only be performed by a qualified electrician. Clean the product with a soft, clean, dry and lint-free cloth. Do not use any cleaning agents containing solvents or abrasive substances. The plastic housing and the labelling could be damaged by it.

13 Declaration of conformity

Oventrop GmbH & Co. KG hereby declares that the appliance complies with the following directive.

- Directive relating to the making available of radio equipment 2014/53/EU.

The complete text of the EU declaration of conformity is available on the Oventrop Internet page.

14 Warranty

Oventrops general conditions of sales and delivery valid at the time of supply are applicable.