

### Application:

The Oventrop boiler connection system Regumat-180 plus DN 32 - pump length 180 mm - allows for a time-, cost- and space-saving connection of the boiler to the pipework. The Regumat-180 plus stations are available with or without high-efficiency pumps.

### Advantages:

- pre-assembled connection system for pumps with a length of 180 mm
- high quality materials
- with pump ball valve at the pump inlet
- universal thermal insulation of modular construction supplied with each "Regumat"
- return pipe with check valve which can be opened manually
- easy installation by use of tailpipe sets
- no hemp sealing
- integrated wall mounting device
- supply and return pipe can be changed on site

### Choice of the Regumat-180 stations:

#### Product assembly DN 32 for pump length 180 mm

The Regumat-180 with pump ball valve is available with or without high-efficiency pump

- as basic model (without mixing valve)
- as model with three-way mixing valve and mounted actuator

Outer dimensions thermal insulation:

H = 626 mm, W = 428 mm, D = 221 mm



Regumat M3-180 plus DN 32

	Model <u>without</u> mixing valve	Model <u>with</u> mixing valve
	Regumat S-180 plus	Regumat M3-180 plus
Isolation device with 2 ball valves and 2 thermometers (without pressure relief device)	X	X
Wall mounting device	X	X
Flanged pipe with check valve	X	
Distance piece	X	
Three-way mixing valve with check valve and and actuator (suitable for standard boiler regulations)		X
Pump ball valve at the pump inlet	X	X
Thermal insulation	X	X

**Tailpipe sets are available as accessories.**

**Tender specification: Regumat S-180 plus DN 32 with pump ball valve - constant temperature heating circuit**

Product assembly for the connection of the boiler to the pipework.

Consisting of: Isolation device with 2 ball valves for the isolation of the heating circuit, 2 thermometers integrated in the handles of the ball valves for flow and return temperature display, pump ball valve at the pump inlet, flanged pipe with check valve in the return pipe to avoid gravity circulation and universal thermal insulation of modular construction.

**Materials:**

Valves and fittings: Brass  
Seals: EPDM

**Connections:**

To heating circuit: G 2 male thread, flat sealing  
To boiler: G 2 male thread, flat sealing  
Pump: G 2 male thread, flat sealing

**Technical data:**

Nominal size: DN 32  
Max. operating pressure: 10 bar (PN 10)  
Max. operating temperature: 95 °C  
Opening pressure check valve: 20 mbar  
k<sub>vs</sub> value: 25  
Recommended application range: max. 190 kW  
( $\Delta T = 20 \text{ K}$ ,  $\Delta p = 100 \text{ mbar}$ )

**Models:**

without high-efficiency pump	<b>Item no.:</b>
with high-efficiency pump (EEI ≤ 0,2)	1355070
Grundfos Magna3 32-100	1355080
Wilo Stratos 30 1-10	1355081

**Function:**

The station allows for the isolation of the supply and return pipe of the heating circuit. The check valve integrated in the return pipe avoids gravity circulation.

**Note:**

When the high-efficiency pump is switched off, a low gravity circulation depending on the circulation pressure is still possible within the heating system as the check valve is not tight sealing. On delivery, the supply pipe is on the right hand side. If required, the supply and the return pipe can be changed on site (see installation instructions).

To avoid malfunctions caused by impurities, the installation of an Oventrop strainer is recommended. The installation has to be flushed thoroughly before commissioning.

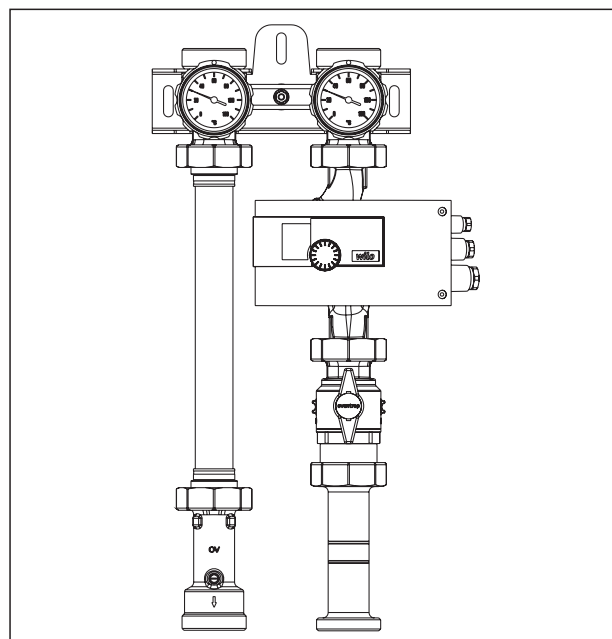

Regumat S-180 plus DN 32 with pump ball valve

**Tender specification: Regumat M3-180 plus DN 32 with pump ball valve - variable temperature heating circuit**

Product assembly for the connection of the boiler to the pipework.

Consisting of: Isolation device with 2 ball valves for the isolation of the heating circuit, 2 thermometers integrated in the handles of the ball valves for flow and return temperature display, pump ball valve at the pump inlet, flanged pipe with check valve in the return pipe to avoid gravity circulation, three-way mixing valve with mounted actuator and universal thermal insulation of modular construction.

**Materials:**

Valves and fittings: Brass  
Seals: EPDM

**Connections:**

To heating circuit: G 2 male thread, flat sealing  
To boiler: G 2 male thread, flat sealing  
Pump: G 2 male thread, flat sealing

**Technical data:**

Nominal size: DN 32  
Max. operating pressure: 10 bar (PN 10)  
Max. operating temperature: 95 °C  
Opening pressure check valve: 20 mbar  
Actuator: 230 V, 90°/140 sec., 15Nm  
K<sub>vs</sub> value: 15  
Recommended application range: max. 110 kW  
( $\Delta T = 20 \text{ K}$ ,  $\Delta p = 100 \text{ mbar}$ )

**Models:**

without high-efficiency pump	<b>Item no.:</b>
with high-efficiency pump (EEI ≤ 0,2)	1355270
Grundfos Magna3 32-100	1355280
Wilo Stratos 30 1-10	1355281

The Regumat M3-130 plus has the same design and function as the Regumat S-130 plus. It is additionally equipped with a three-way mixing valve with check valve and mounted actuator. The three-way mixing valve serves to control the flow temperature.

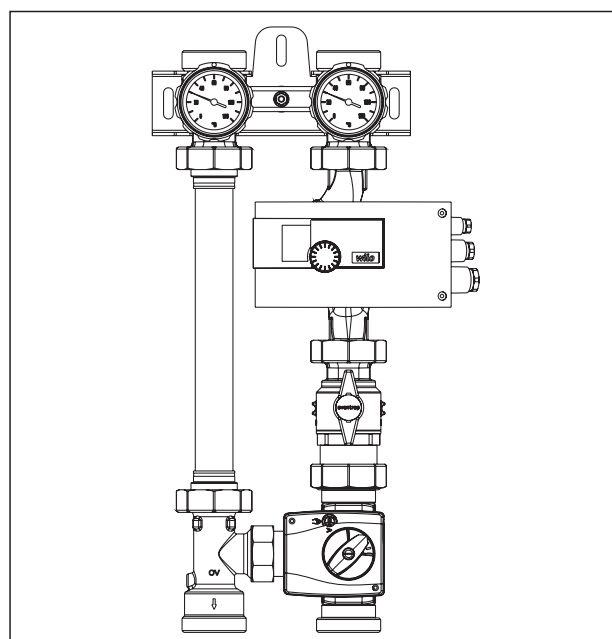

Regumat M3-180 plus DN 32 with pump ball valve

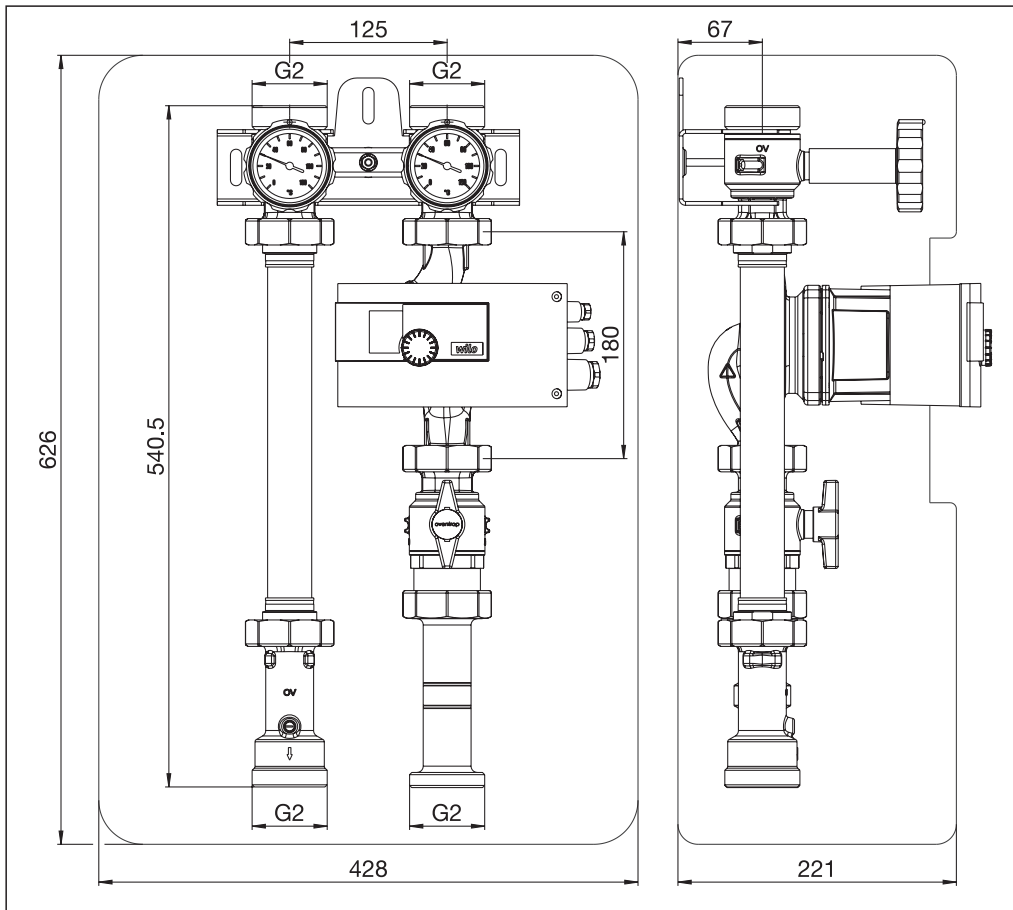

Dimensions Regumat S-180 plus DN 32

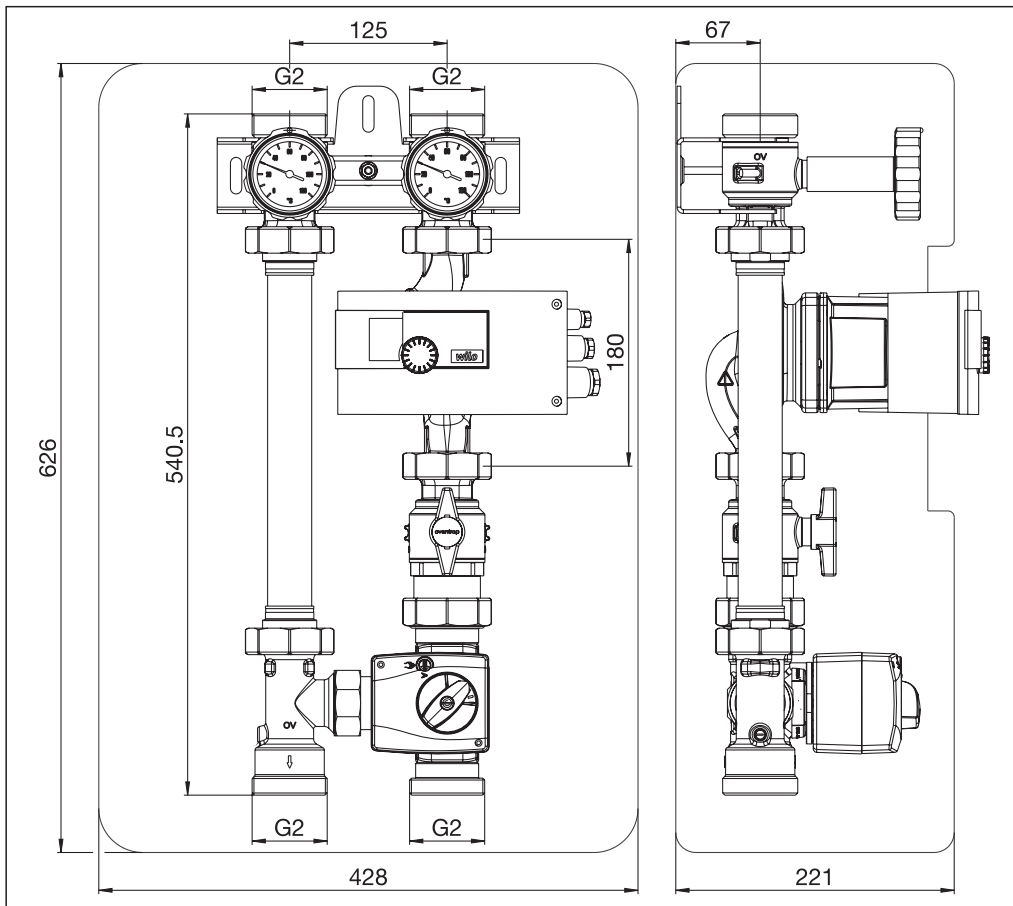

Dimensions Regumat M3-180 plus DN 32

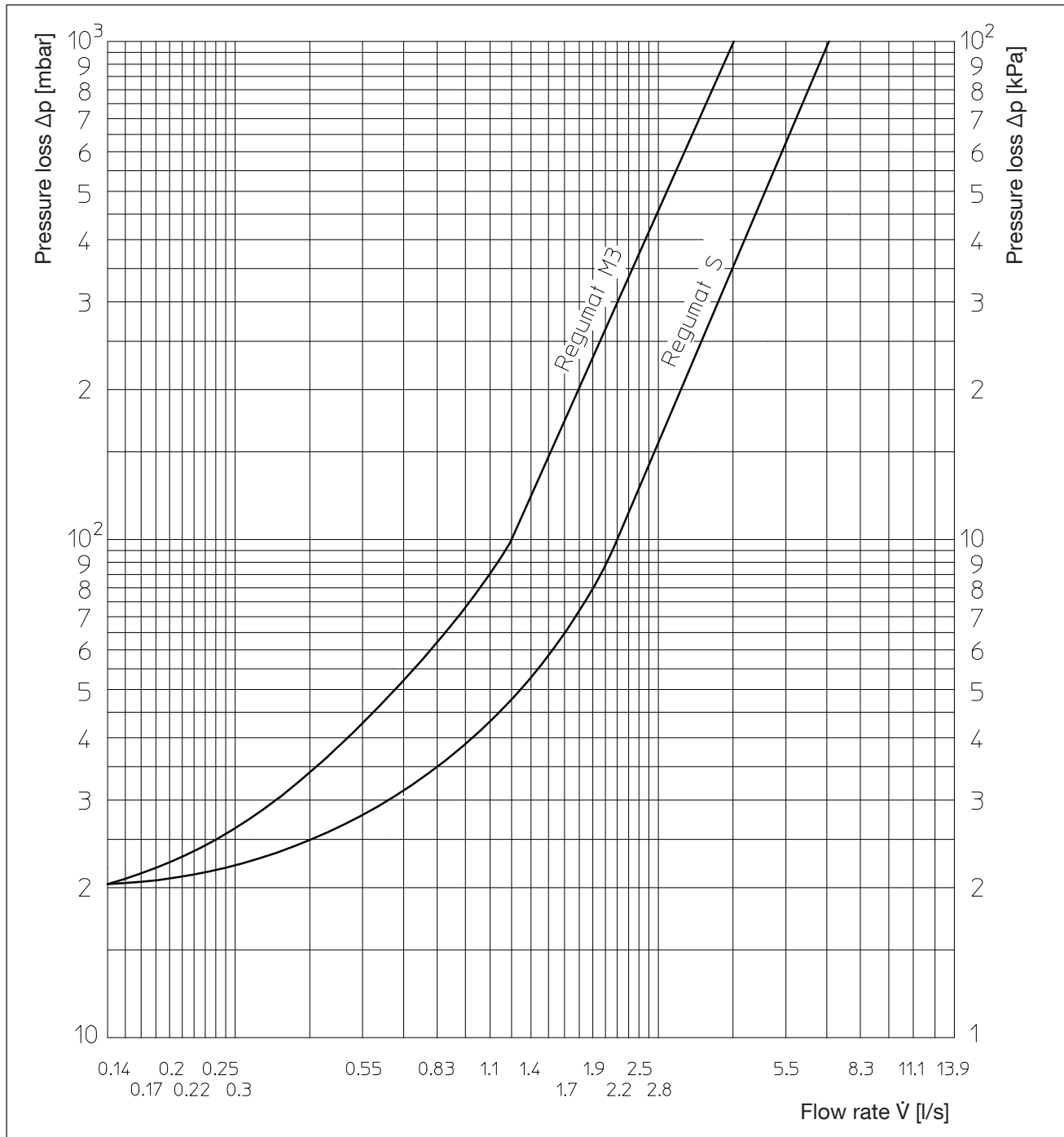

Flow chart

**Tailpipe sets are available as accessories.**

Subject to technical modifications without notice.

Product range 3.1  
ti 392-EN/10/MW  
Edition 2020