

Application:

The Oventrop boiler connection system Regumat-130 DN 25 - pump length 130 mm - allows for a time-, cost- and space-saving connection of the boiler to the pipework. The Regumat-130 stations are available with or without high-efficiency pumps.

Advantages:

- pre-assembled connection system for pumps with a length of 130 mm
- high quality materials
- insulation made of expanded polypropylene (EPP) supplied with each Regumat
- easy installation by use of tailpipe sets
- no hemp sealing
- supply and return pipe can be changed on site

Choice of the Regumat-130 stations:

Product assembly DN 25 for pump length 130 mm

- The Regumat-130 is available with or without high-efficiency pump
- as basic model (without mixing valve)
- as model with three-way mixing valve with bypass with manual presetting and mounted actuator

Outer dimensions thermal insulation:

H = 364 mm, W = 248 mm, D = 197 mm



Regumat M3-130 DN 25

	Model <u>without</u> mixing valve	Model <u>with</u> mixing valve
	Regumat S-130	Regumat M3-130
Isolation device with 2 ball valves and 2 thermometers (without pressure relief device)	X	X
Flanged pipe with check valve	X	X
Three-way mixing valve with bypass with manual presetting and actuator (suitable for standard boiler regulations)		X
Distance piece	X	
Thermal insulation	X	X

Tailpipe sets are available as accessories.

Tender specification: Regumat S-130 DN 25 - constant temperature heating circuit

Product assembly for the connection of the boiler to the pipework.

Consisting of: Isolation device with 2 ball valves for the isolation of the heating circuit, 2 thermometers integrated in the handles of the ball valves for flow and return temperature display, flanged pipe with check valve in the return pipe to avoid gravity circulation and insulation with interchangeable plugs in red and blue for change of supply and return pipe.

Materials:

Valves and fittings: Brass
Seals: EPDM

Connections:

To heating circuit: G 1½ male thread, flat sealing
To boiler: G 1½ male thread, flat sealing
Pump: G 1½ male thread, flat sealing

Technical data:

Nominal size: DN 25
Max. operating temperature: 95 °C
Max. operating pressure: 10 bar (PN 10)
Opening pressure check valve: 20 mbar
 k_{vs} value: 7.4
Recommended application range: max. 50 kW
($\Delta T = 20$ K, $\Delta p = 100$ mbar)

Models:

without high-efficiency pump	Item no.: 1355071
with high-efficiency pump (EEI ≤ 0.2) Wilo PARA 25-130/6-43/SC-9	1355074

Function:

The station allows for the isolation of the supply and return pipe of the heating circuit. The check valve integrated in the return pipe avoids gravity circulation.

Note:

When the high-efficiency pump is switched off, a low gravity circulation depending on the circulation pressure is still possible within the heating system as the check valve is not tight sealing. On delivery, the supply pipe is on the right hand side. If required, the supply and the return pipe can be changed on site (see installation instructions).

To avoid malfunctions caused by impurities, the installation of an Oventrop strainer is recommended. The installation has to be flushed thoroughly before commissioning.

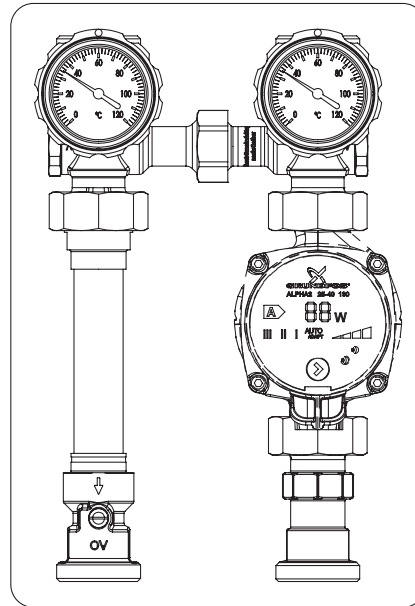

Regumat S-130

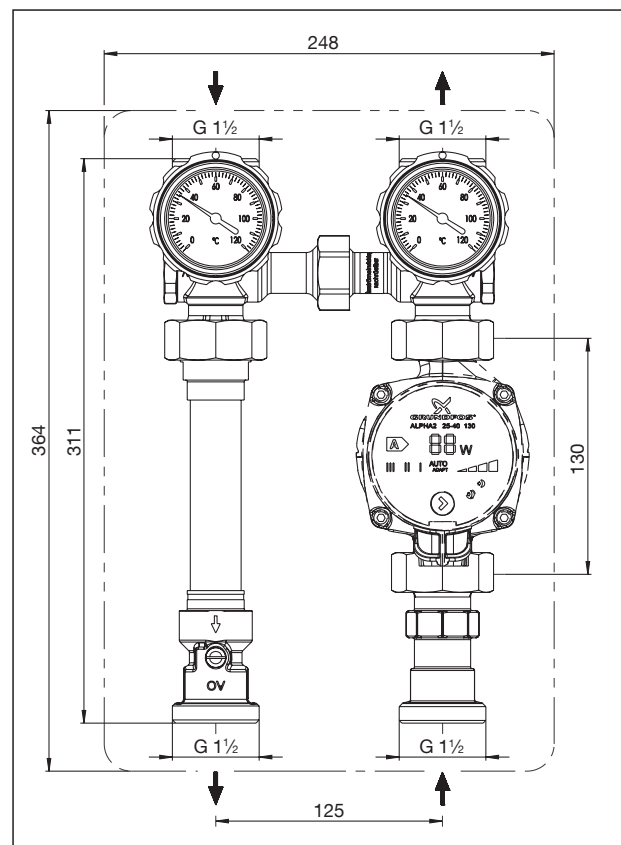

Dimensions Regumat S-130 DN 25

Tender specification: Regumat M3-130 DN 25 - variable temperature heating circuit

Product assembly for the connection of the boiler to the pipework.

Consisting of: Isolation device with 2 ball valves for the isolation of the heating circuit, 2 thermometers integrated in the handles of the ball valves for flow and return temperature display, flanged pipe with check valve in the return pipe to avoid gravity circulation, three-way mixing valve with bypass with manual presetting and mounted actuator as well as insulation with interchangeable plugs in red and blue for change of supply and return pipe.

Materials:

Valves and fittings:

Brass

Seals:

EPDM

Connections:

To heating circuit:

G 1½ male thread, flat sealing

To boiler:

G 1½ male thread, flat sealing

Pump:

G 1½ male thread, flat sealing

Technical data:

Nominal size:

DN 25

Max. operating temperature:

95 °C

Max operating pressure:

10 bar (PN 10)

Opening pressure check valve:

20 mbar

Actuator:

230 V, 90°/140 sec., 5 Nm

k_{vs} value:

4.3

Recommended application

range:

max. 40 kW
($\Delta T = 20 \text{ K}$, $\Delta p = 100 \text{ mbar}$)

Models:

without high-efficiency pump

Item no.:

1355271

with high-efficiency pump ($EEL \leq 0.2$)

Wilo PARA25-130/6-43/SC-9

1355274

Function:

The Regumat M3-130 has the same design and function as the Regumat S-130. It is additionally equipped with a three-way mixing valve with mounted actuator. The three-way mixing valve serves to regulate the flow temperature and has a bypass with manual presetting. A manually set return flow share can be added to the supply pipe via this bypass in order to reduce the temperature of a surface heating for instance.

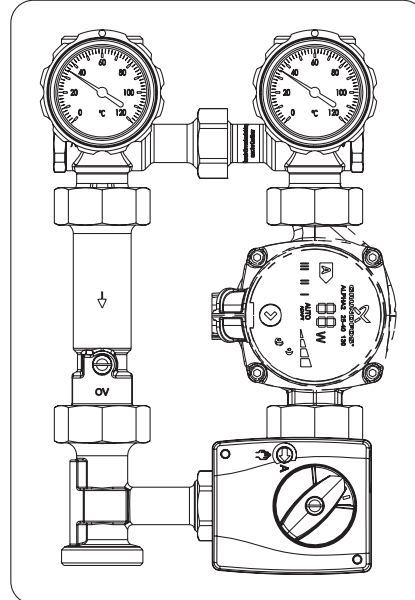

Regumat M3-130

As for the model with mixing valve (M3-130), the mixing valve is fully open.

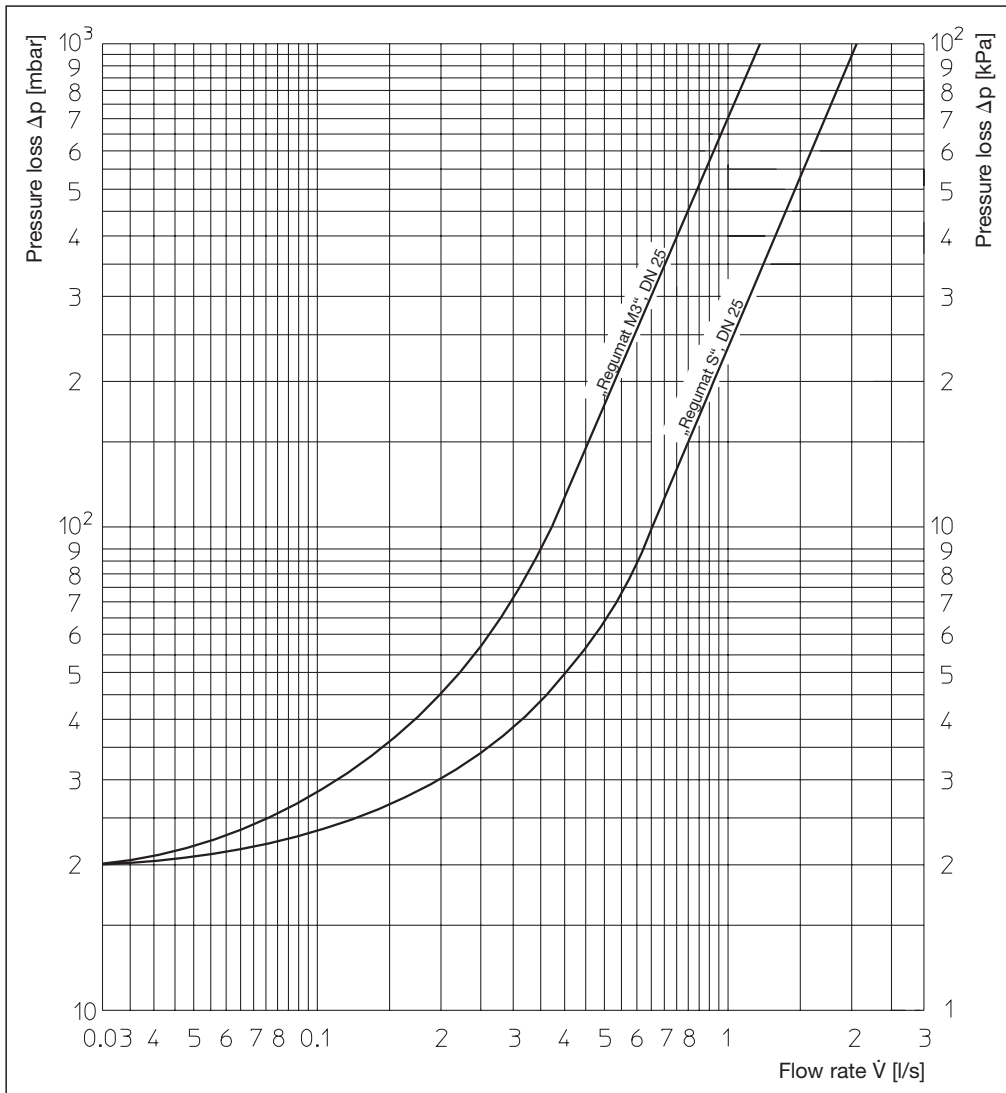

Flow chart Regumat-130 DN 25

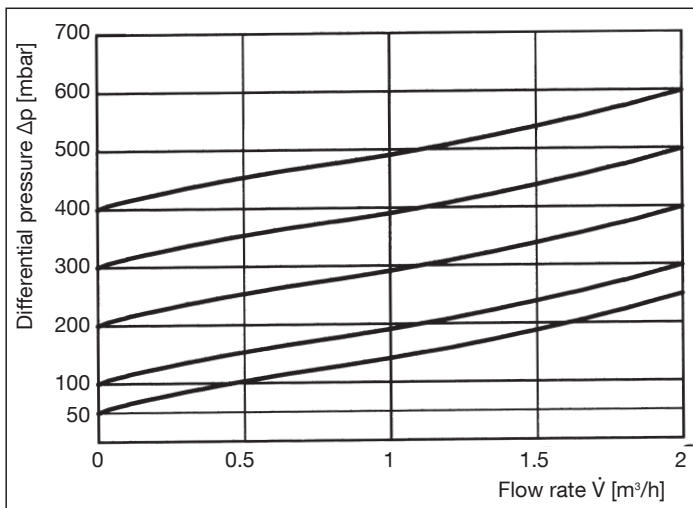

Flow chart bypass (pressure relief device)

Wall mounting device:

For mounting the Regumat DN 25 onto the wall, a wall mounting device, item no. 1352096, is available.

Tailpipe sets are available as accessories.

Subject to technical modifications without notice.

Product range 3.1
 ti 137-EN/10/MW
 Edition 2020